

## swivel joint

## type 30-3000

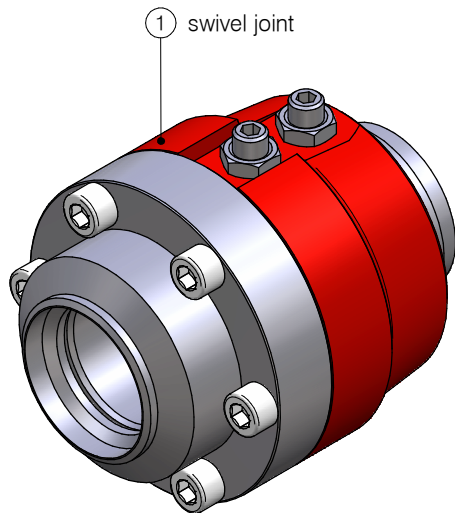

ITEM	SPECIFICATIE
afmetingen	DN50 (2"), DN80 (3"), DN100 (4")
swivel flens	rvs 1.4571
binnenbus	rvs 1.4571
buitenbus	staal 42CrMo4
seals	PTFE, grafiet, Kalrez
eind verbinding	flenzen ANSI/DIN, laseinden

PROCESGEGEVENS	WAARDEN
druk	tot 50 bar
temperatuur (PTFE)	-50°C / +200°C
temperatuur (grafiet/Kalrez)	-40°C / +320°C

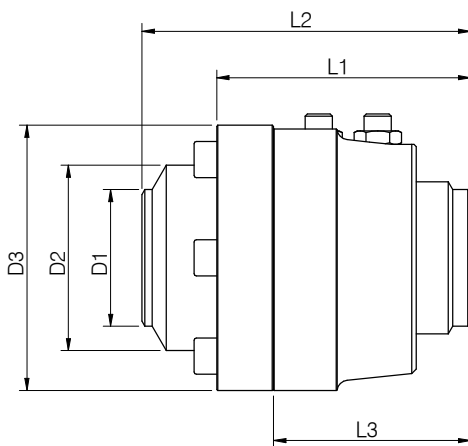

MAAT		AFMETINGEN							GEWICHT	
		D1	D2	D3	L1	L2	L3	S	swivel joint	mid part
mm	inch	mm	mm	mm	mm	mm	mm	mm	kg	kg
50	2"	60	82	117	112	145	87	2,77 / 3,54	5,2	3,5
80	3"	89	116	152	112	155	87	3,05 / 5,94	8,0	5,0
100	4"	114	139	175	112	160	87	3,05 / 6,02	10,0	6,6

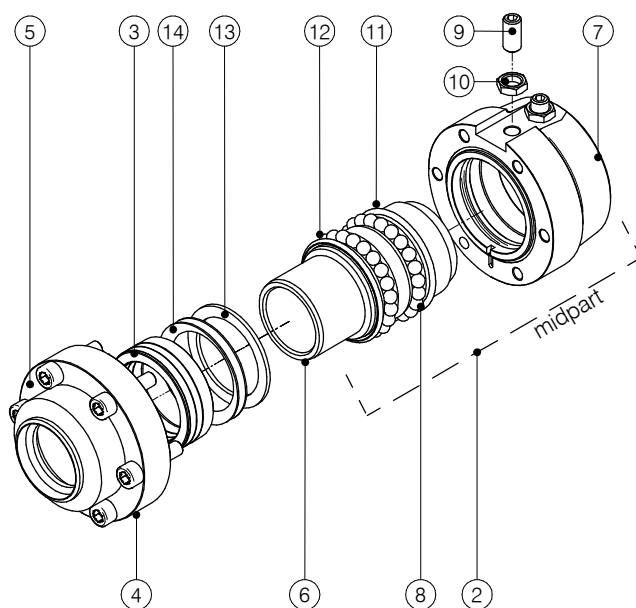

ITEM	NAAM	AANTAL		
		50	80	100
2	midpart	1	1	1
3	product seal, PTFE	1	1	1
3	product seal, grafiet	1	1	1
4	swivel flens	1	1	1
5	bout	6	8	10
6	binnenbus *	1	1	1
7	buitenbus *	1	1	1
8	kogel	44	64	78
9	kogelplug	2	2	2
10	moer	2	2	2
11	stof seal, PTFE	1	1	1
11	stof seal, Kalrez	1	1	1
12	kamer seal, PTFE	1	1	1
12	kamer seal, Kalrez	1	1	1
13	veer	1	1	1
14	druk afdichting	1	1	1

\* alleen leverbaar als onderdeel van gehele swivel excl. flens

technische modificaties voorbehouden