

## bodemlaadarm

## type TM

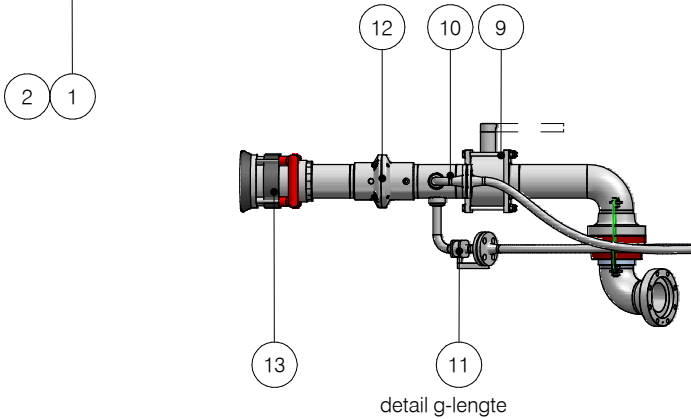
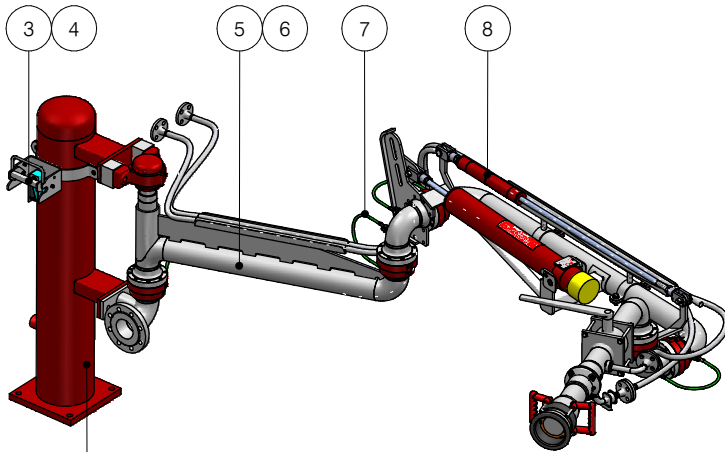

ITEM	SPECIFICATIE
afmetingen	DN50 (2"), DN80 (3"), DN100 (4")
materiaal	rvs, staal, PTFE gelined
aansluiting	flenzen ANSI/DIN
swivel joint	30-2000 (standaard), 30-3620 (PTFE gelined), 30-0470 (lage inbouw)
seals	PTFE, Viton, EPDM
balancing	veercilinder

PROCESGEGEVENS	WAARDEN
druk	tot 50 bar
temperatuur	-50°C / +200°C

NR.	OPTIES
1	standpoot
2	wandconsole
3	parkeervergrendeling
4	parkeerstanddetectie
5	stoom tracing, stoom jacketing, elektrische tracing
6	isolatie
7	aardkabel
8	G-lengte balancing
9	afsluiter
10	drain-aansluiting
11	purge-aansluiting
12	break-away koppeling
13	koppeling

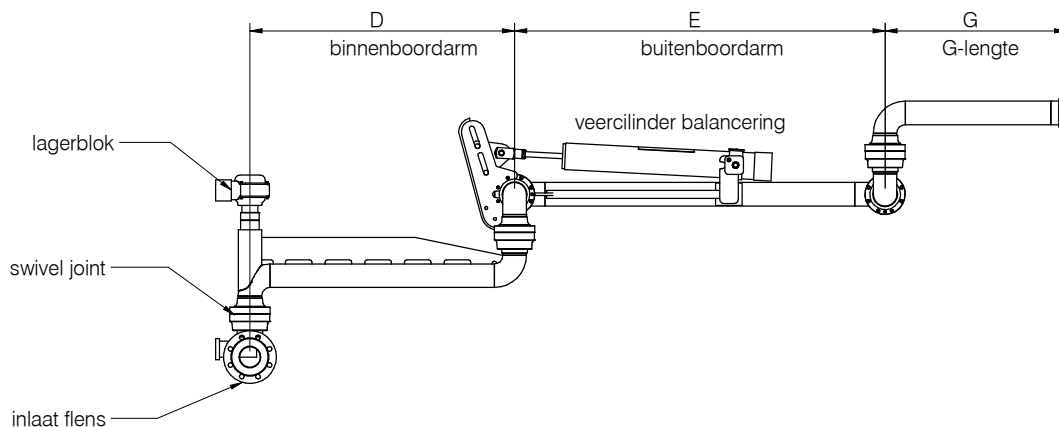
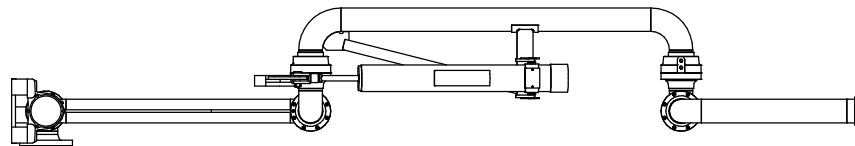

technische modificaties voorbehouden