

ITEM	SPEZIFIKATION
Abmessungen	DN25 (1"), DN50 (2"), DN80 (3")
Werkstoffe	Edelstahl, Stahl (coated/galvanisiert)
Anschlüsse	ANSI-/DIN-Flansch
Drehgelenk	30-2000 (standard)
Dichtungen	PTFE, Viton, EPDM
Schlauch	PP composite

PROZESSDATEN	WERT/GRÖßE
Druck	bis 10 bar
Temperatur	-30°C / +80°C

NR.	BENENNUNG
1	Anschluß
2	Drehgelenk
3	Haspel (inkl. Federmotor)
4	Hauptgelenk
5	Stützrahmen
6	Schlauch
7	Absperrventil (optionen)
8	Sicherheitstrennkupplung (optionen)
9	Kupplung / Flansch (optionen)
10	Erdungsnock

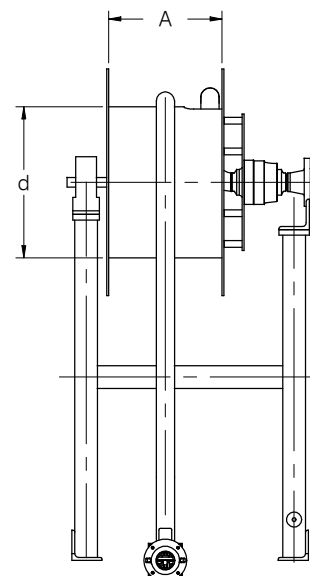
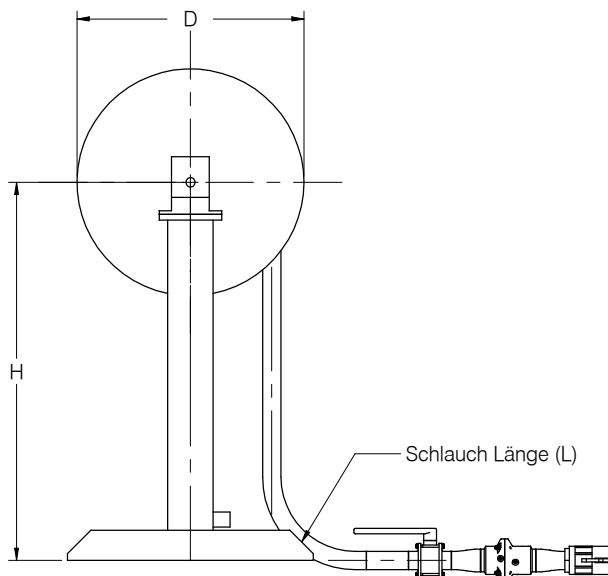

technische Änderungen vorbehalten

NUMBER <b>DS.TH.02.D</b>	REV. <b>0</b>	PAGE <b>1 / 1</b>	DATE <b>30/05/05</b>	<b>WLT Liquid &amp; Gas Loading Technology B.V.</b> PO Box 24, 2820 AA Stolwijk, the Netherlands tel : +31(0)182-354440 e-mail: mail@wlt.nl fax: +31(0)182-354480 website: www.wlt.nl
-----------------------------	------------------	----------------------	-------------------------	--