

UNISERT® ASSEMBLY

2-2203-2

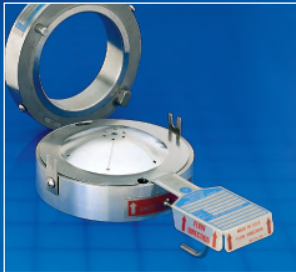

**Continental Disc®
Corporation**

Performance Under Pressure®

UNISERT ASSEMBLY

What is the UNISERT Assembly?

The UNISERT Assembly is a flat seat rupture disc holder which provides improved rupture disc sealing capabilities. It is designed to house either the MICRO X® Rupture Disc or the Composite Flat Seat Rupture Disc. These non-fragmenting designed rupture discs provide a wide choice of burst ratings from the low pressures of the Composite (FS) Rupture Disc through the higher pressures of the scored positive acting MICRO X Rupture Disc.

One Holder—But Variable Rupture Disc Design Options

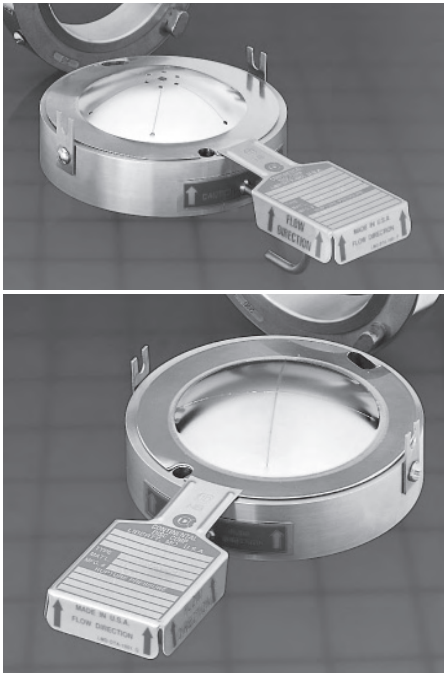

The UNISERT Assembly is available in nominal sizes ranging from 1" through 36" for installation between ANSI, DIN, or JIS class companion flanges. Standard materials for the UNISERT Holder include 316 Stainless Steel, Carbon Steel, Monel®, and Hastelloy C*** (Reference Table V, pages 7 - 10).

INSTALLATION FEATURES

J-Hook and Alignment Pins

One feature the UNISERT Assembly offers is alignment pins for correct rupture disc orientation into the UNISERT Holder. The UNISERT Holder is also equipped with a J-Hook for proper indexing and

flow orientation between the companion flanges. Both the J-Hook and alignment pins are provided on all 1" through 12" UNISERT Holders.

Tagging

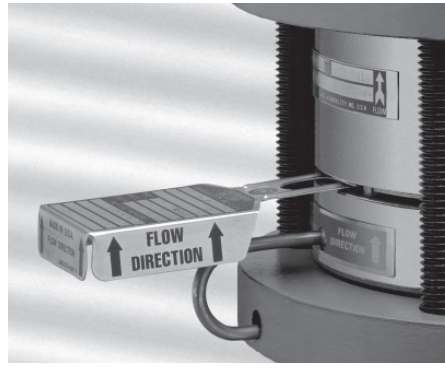

The UNISERT Holder is supplied with a permanently attached stainless steel nameplate with arrows that indicate flow direction. In addition, the Composite (FS) and MICRO X rupture discs are supplied with a three-dimensional flow direction tag. Directional arrows on both the tag and nameplate provide a means to visually verify the rupture disc assembly is properly oriented in your system (see above photo).

In accordance with customer specifications, pertinent identification information will be stamped on the rupture disc and holder tags (see above photo).

Application Flexibility

In the event that there is a change in system operating requirements, the flexibility of the UNISERT Assembly permits utilization of various rupture disc types in order to meet a wide range of burst pressures. The Composite (FS) Rupture Disc may be selected for handling very low burst pressures, and the MICRO X Rupture Disc can be utilized for higher pressures. Thus, the type of rupture disc can be changed rather than replacing the existing holder.

What is a MICRO X Rupture Disc ?

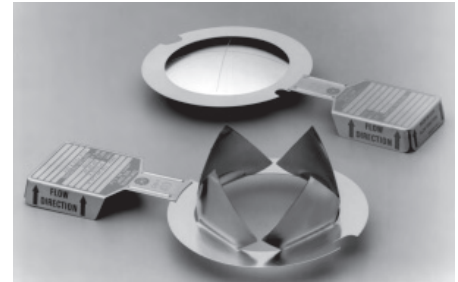

The MICRO X Rupture Disc is a flat seat cross-scored, tension-type rupture disc. The MICRO X Rupture Disc is designed to provide a full, non-fragmenting, four petal opening pattern. Because the MICRO X Rupture Disc is scored on the outlet (vent) side of the rupture disc, a smooth disc surface is provided on the inlet (process) side of the rupture disc. The result is an undisturbed inlet surface resistant to corrosion and the accumulation of process media.

What is a Composite Rupture Disc?

The Composite Rupture Disc for a Unisert Holder has a flat seat configuration and consists of two or more metallic or non-metallic components. The components typically consist of a metallic top section and metallic or non-metallic seal, with an optional vacuum support, protective rings, gaskets or outlet liner.

Patented Seven-Hole*** Design

Continental Disc Corporation's Composite (FS) Rupture Disc top section is manufactured with a patented seven-hole pattern, and with six pre-cut sections providing a non-fragmenting design when used with a non-metallic or Teflon® **** seal. With the seven-hole pattern, heavier materials of construction can be used. This results in a higher operating to burst pressure ratio – up to 80%.

* Monel is a registered trademark of the Inco family of companies.

** Hastelloy is a registered trademark of Haynes International.

*** United States patent no. 3,445,032

**** Teflon is a registered trademark of E.I. du Pont de Nemours and Company used under license.

Composite Flat Seat Rupture Disc Types

Continental Disc Corporation manufactures several types of prebulged flat seat rupture discs.

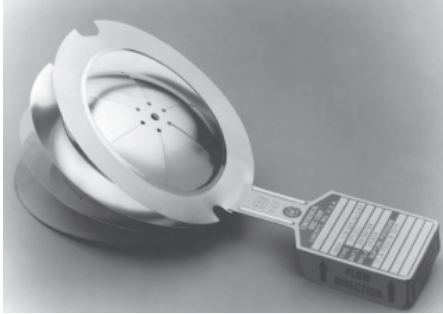

Type CDC is the basic Composite Rupture Disc, consisting of a slotted metal top section and a Teflon or metal seal located on the process side of the top section.

Type CDCV is the same as a CDC Type Rupture Disc, with a vacuum support installed on the process side of the top section and seal.

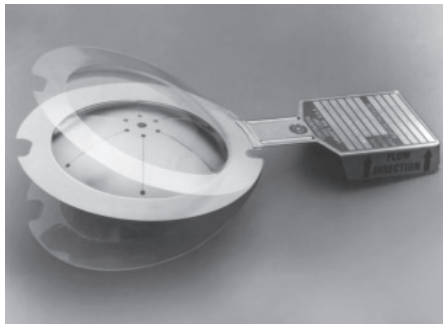

Type PL is basically the same as the CDC Type Rupture Disc, with the addition of a corrosion resistant Teflon liner on the outlet side of the top section.

Type PLV is the same as the PL Type Rupture Disc, but capable of withstanding full vacuum. The PLV is constructed in the same manner as the PL except a vacuum support is located on the outlet side of the top section. The outlet liner is positioned on top of the vacuum support, protecting the metal top section and the vacuum support from corrosive media.

The MICRO X and Composite Flat Seat rupture discs incorporate a number of outstanding features:

- Excellent for use in gaseous or liquid service
- 80% operating to burst pressure ratio
- Excellent corrosion resistance
- Non-fragmenting design*
- Full, instantaneous opening
- Excellent for use under relief valves
- Permanently attached 3-dimensional flow direction tag is standard

* The non-fragmenting design applies to all MICRO X Rupture Discs, but only to Composite (FS) Rupture Discs supplied with a non-metallic seal.

Recommended Maximum Temperatures

Generally, the burst pressure of a rupture disc will decrease as operating temperatures increase. Table I states the maximum temperatures for commonly used rupture disc materials, liners, and seals.

Table I - Temperature Limits

Material	°F	°C
Nickel, Monel	800	427
Inconel	1000	538
316SS	900	482
FEP Teflon Liner or Seal	400	204
TFE or PFA Teflon Liner or Seal	500	260
Aluminum or Silver Seal	260	127

Rupture Disc Options

Sizes/Materials—The MICRO X and Composite (FS) rupture discs manufactured for use with the Unisert Holder are available in nominal sizes ranging from 1" (25mm) through 36" (900mm). Standard materials of construction are 316 Stainless Steel, Monel, Nickel and Inconel^{®**}. Consult Table II & III for minimum and maximum burst pressures for MICRO X and Composite (FS) rupture discs.

Liners—Continental Disc Corporation offers protective liners to provide additional protection from the effect corrosives might have on the performance of the rupture disc. Typically, liners are made of Teflon.

Protective Rings—Protective rings may be used with rupture discs made of thin materials or in instances where delicate liners or seals are used. These rings protect the rupture disc from foreign material in the sealing area where holders may be pitted or corroded from extended use.

Vacuum Support—Thin materials of construction generally require use of a vacuum support to preclude damage to the rupture disc and ensure proper operation when a system vacuum occurs. CDC vacuum supports are manufactured to withstand a full system vacuum and will be supplied when the application requires a vacuum support. Each vacuum support is mated with a specific rupture disc and is attached to that rupture disc. When ordering a MICRO X Rupture Disc (sizes 6" and above) or Composite (FS) Rupture Disc that will be subjected to a vacuum condition, clearly specify the exact conditions that the rupture disc will encounter. For backpressure conditions higher than 14.7 psig (1 barg), consult your Continental Disc representative or the factory.

Gaskets—Gaskets may be used to provide additional sealing and prevent leakage through the seating area of a scratched or pitted holder. They are located on the process side of the rupture disc and are usually manufactured from Teflon. Other materials are available upon request.

** Inconel is a registered trademark of the Inco family of companies.

PRESSURE RANGES

Table II - MICRO X Rupture Disc Minimum / Maximum Burst Pressures

White bar indicates "psig" - Gray bar indicates "barg"

RUPTURE DISC NOMINAL SIZE	RUPTURE DISC MINIMUM WITH OR WITHOUT VACUUM SUPPORT ¹				RUPTURE DISC MINIMUM TO WITHSTAND FULL VACUUM WITHOUT VACUUM SUPPORT				MAXIMUM PRESSURE			
	Nickel	Monel	Inconel	316SS	Nickel	Monel	Inconel	316SS	Nickel	Monel	Inconel	316SS
1 in.	190	285	355	450	190	285	355	450	2650	3150	3600	3600
25mm	13,1	19,7	24,5	31,0	13,1	19,7	24,5	31,0	183	217	248	248
1-1/2 in.	145	210	265	270	145	210	265	270	1950	2300	2700	2800
40mm	10,0	14,5	18,3	18,6	10,0	14,5	18,3	18,6	134	159	186	193
2 in.	85	125	155	170	85	125	155	170	1500	1800	2050	2150
50mm	5,86	8,62	10,7	11,7	5,86	8,62	10,7	11,7	103	124	141	148
3 in.	65	90	110	130	65	90	110	130	1050	1250	1440	1440
80mm	4,48	6,21	7,58	8,96	4,48	6,21	7,58	8,96	72,4	86,2	99,3	99,3
4 in.	55	75	90	95	55	75	90	95	850	1000	1150	1200
100mm	3,79	5,17	6,21	6,55	3,79	5,17	6,21	6,55	58,6	68,9	79,3	82,7
6 in.	55	55	75	75	100	100	175	175	600	700	800	800
150mm	3,79	3,79	5,17	5,17	6,89	6,89	12,1	12,1	41,4	48,3	55,2	55,2
8 in.	50	55	65	75	100	100	175	175	450	525	600	600
200mm	3,45	3,79	4,48	5,17	6,89	6,89	12,1	12,1	31,0	36,2	41,4	41,4
10 in.	45	45	60	60	95	100	175	175	360	420	480	480
250mm	3,10	3,10	4,14	4,14	6,55	6,89	12,1	12,1	24,8	29,0	33,1	33,1
12 in.	40	40	50	50	95	100	175	175	300	350	400	400
300mm	2,76	2,76	3,45	3,45	6,55	6,89	12,1	12,1	20,7	24,1	27,6	27,6
14 in.	21	27	34	33	170	—	—	—	170	170	170	170
350mm	1,45	1,86	2,34	2,28	11,7	—	—	—	11,7	11,7	11,7	11,7
16 in.	18	23	30	29	145	—	—	—	170	170	170	170
400mm	1,24	1,59	2,07	2,00	10,0	—	—	—	11,7	11,7	11,7	11,7
18 in.	16	21	26	26	130	—	—	—	165	165	165	165
450mm	1,10	1,45	1,79	1,79	8,96	—	—	—	11,4	11,4	11,4	11,4
20 in.	15	19	24	23	120	—	—	—	165	165	165	165
500mm	1,03	1,31	1,65	1,59	8,27	—	—	—	11,4	11,4	11,4	11,4
24 in.	15	19	24	23	130	—	—	—	135	135	135	135
600mm	1,03	1,31	1,65	1,59	8,96	—	—	—	9,31	9,31	9,31	9,31
28 in.	15	19	24	23	110	—	—	—	135	135	135	135
700mm	1,03	1,31	1,65	1,59	7,58	—	—	—	9,31	9,31	9,31	9,31
30 in.	15	19	24	23	—	—	—	—	120	120	120	120
750mm	1,03	1,31	1,65	1,59	—	—	—	—	8,27	8,27	8,27	8,27
32 in.	15	19	24	23	—	—	—	—	110	110	110	110
800mm	1,03	1,31	1,65	1,59	—	—	—	—	7,58	7,58	7,58	7,58
36 in.	15	19	24	23	—	—	—	—	100	100	100	100
900mm	1,03	1,31	1,65	1,59	—	—	—	—	6,89	6,89	6,89	6,89

Notes for Table II:

1. Vacuum supports are required in order for rupture disc to withstand full vacuum when the rupture disc rating is below the value stated in column two: "to withstand full vacuum without a vacuum support."
2. Minimum pressures stated in the table are based upon the minimum of the manufacturing range at 72°F (22°C). MICRO X Flat Seat Rupture Discs specified at a minimum setting will have the manufacturing range added above the minimum pressure.
3. For information concerning conditions not shown, please contact your Continental Disc Corporation representative or the factory.

Table III - Minimum / Maximum Pressures for Composite Flat Seat Rupture Discs

White bar indicates "psig" - Gray bar indicates "barg"

RUPTURE DISC NOMINAL SIZE	MINIMUM PRESSURES FOR COMPOSITE RUPTURE DISCS WITH TEFLON SEALS @ 72° F (22° C)								MINIMUM PRESSURES FOR COMPOSITE RUPTURE DISCS WITH METAL SEALS @ 72° F (22° C)						MAXIMUM PRESSURES FOR COMPOSITE RUPTURE DISCS @ 72°F (22°C)	
	CDC		CDCV		PL		PLV		Aluminum	Silver	Nickel	Monel	Inconel	316SS	With Teflon Seal	With Metal Seal
	TFE	FEP, PFA	TFE	FEP, PFA	TFE	FEP, PFA	TFE	FEP, PFA								
1 in.	25	30	30	35	35	40	60	80	38	150	190	230	292	442	500	1440
25mm	1,72	2,07	2,07	2,41	2,41	2,76	4,14	5,52	2,62	10,3	13,1	15,9	20,1	30,5	34,5	99,3
1-1/2 in.	22	27	26	35	32	38	60	75	29	100	130	150	208	228	500	1440
40mm	1,52	1,86	1,79	2,41	2,21	2,62	4,14	5,17	2,00	6,89	8,96	10,3	14,3	15,7	34,5	99,3
2 in.	7	15	10	18	15	20	28	35	17	60	78	90	124	208	290	1100
50mm	0,483	1,03	0,689	1,24	1,03	1,38	1,93	2,41	1,17	4,14	5,38	6,21	8,55	14,3	20,0	75,8
3 in.	6	8	8	11	11	16	18	25	13	45	59	65	98	130	160	900
80mm	0,414	0,552	0,552	0,758	0,758	1,10	1,24	1,72	0,896	3,10	4,07	4,48	6,76	8,96	11,0	62,1
4 in.	5	7	7	8	6	9	15	18	9	34	46	52	72	98	160	720
100mm	0,345	0,483	0,483	0,552	0,414	0,621	1,03	1,24	0,621	2,34	3,17	3,59	4,96	6,76	11,0	49,7
6 in.	3	4	5	7	5	7	12	14	7	26	33	39	56	65	130	640
150mm	0,207	0,276	0,345	0,483	0,345	0,483	0,827	0,965	0,483	1,79	2,28	2,69	3,86	4,48	8,97	44,1
8 in.	2	3	5	5	4	5	11	11	5	20	26	30	39	52	110	590
200mm	0,138	0,207	0,345	0,345	0,276	0,345	0,758	0,758	0,345	1,38	1,79	2,07	2,69	3,59	7,59	40,7
10 in.	—	3	—	5	—	5	—	8	5	—	21	22	33	46	90	480
250mm	—	0,207	—	0,345	—	0,345	—	0,552	0,345	—	1,45	1,53	2,28	3,17	6,21	33,1
12 in.	—	2	—	4	—	5	—	8	4	—	17	20	29	39	80	400
300mm	—	0,138	—	0,276	—	0,345	—	0,552	0,276	—	1,17	1,38	2,00	2,69	5,52	27,6
14 in.	—	2.0	—	4.0	—	5.0	—	8.0	4.0	—	14	17	27	36	70	275
350mm	—	0,138	—	0,276	—	0,345	—	0,552	0,276	—	0,965	1,17	1,86	2,48	4,83	19,0
16 in.	—	2.0	—	4.0	—	5.0	—	8.0	4.0	—	13	16	25	34	60	275
400mm	—	0,138	—	0,276	—	0,345	—	0,552	0,276	—	0,896	1,10	1,72	2,34	4,14	19,0
18 in.	—	2.0	—	4.0	—	5.0	—	8.0	4.0	—	12	14	22	31	50	275
450mm	—	0,138	—	0,276	—	0,345	—	0,552	0,276	—	0,827	0,965	1,52	2,14	3,45	19,0
20 in.	—	2.0	—	4.0	—	5.0	—	8.0	4.0	—	10	12	21	29	50	275
500mm	—	0,138	—	0,276	—	0,345	—	0,552	0,276	—	0,689	0,827	1,45	2,00	3,45	19,0
24 in.	—	2.0	—	4.0	—	5.0	—	8.0	4.0	—	—	—	—	—	50	150
600mm	—	0,138	—	0,276	—	0,345	—	0,552	0,276	—	—	—	—	—	3,45	10,3
28 in.	—	2.0	—	4.0	—	5.0	—	8.0	4.0	—	—	—	—	—	50	—
700mm	—	0,138	—	0,276	—	0,345	—	0,552	0,276	—	—	—	—	—	3,45	—
30 in.	—	2.0	—	4.0	—	5.0	—	8.0	4.0	—	—	—	—	—	50	—
750mm	—	0,138	—	0,276	—	0,345	—	0,552	0,276	—	—	—	—	—	3,45	—
32 in.	—	2.0	—	4.0	—	5.0	—	8.0	4.0	—	—	—	—	—	50	—
800mm	—	0,138	—	0,276	—	0,345	—	0,552	0,276	—	—	—	—	—	3,45	—
36 in.	—	2.0	—	4.0	—	5.0	—	8.0	4.0	—	—	—	—	—	50	—
900mm	—	0,138	—	0,276	—	0,345	—	0,552	0,276	—	—	—	—	—	3,45	—

Notes for Table III:

1. Minimum pressures in the table are based upon the minimum of the manufacturing range @ 72°F (22°C). Composite (FS) Rupture Discs specified at a minimum setting will have the manufacturing range added above the minimum pressure. Example: A 3-inch (80mm) CDC rupture disc with an FEP seal requested to burst at 8 psig (.55 barg) @ 72°F (22°C) would have a standard manufacturing range of 8 psig (.55 barg) to 14.4 psig (1.0 barg).
2. Maximums apply only to Nickel, Monel, Inconel, and 316SS. Consult your Continental Disc Corporation representative or the factory for maximums that apply to other materials.
3. For information concerning conditions not shown, please contact your Continental Disc Corporation representative or the factory.

SPECIFICATIONS

Manufacturing Range

Manufacturing range is defined as the allowable pressure range within which a rupture disc is rated. It is based upon the customer specified burst pressure. The standard manufacturing ranges for Continental's MICRO X Rupture Disc include -5 psig for burst pressure ratings below 50 psig and -10% for burst pressures 50 psig and above. Manufacturing ranges of -2 psig for burst pressure ratings below 50 psig and -5% for burst pressures 50 psig and above are also available. The manufacturing ranges for Continental's Composite (FS) Rupture Discs are outlined in Table IV.

Burst Tolerance

After the rupture disc has been manufactured and tested, it is stamped with the rated burst pressure. The rated (marked) burst pressure is established by bursting a minimum of two discs per lot and averaging the actual burst results. This average burst pressure is the rated (marked) burst pressure which will appear on the rupture disc tag. The burst tolerance applies to the rated (marked) burst pressure.

As per ASME Code, Composite (FS) Rupture Discs and MICRO X Rupture Discs are designed with a burst tolerance

of ± 2 psig (0,138 barg) for pressures up to and including 40 psig (2,76 barg) and $\pm 5\%$ for burst pressures above 40 psig (2,76 barg). Burst tolerances for Composite Rupture Discs rated below 15 psig (1,03 barg) are outlined in Table IV. The burst tolerance applies only to the rated (marked) burst pressure on the rupture disc.

Table IV - Manufacturing Range / Burst Tolerance @ 72°F (22°C) for Composite Flat Seat Rupture Discs

RUPTURE DISC TYPE	SPECIFIED BURST PRESSURE RATING		MANUFACTURING RANGE		BURST TOLERANCE
	psig	barg	% Under	% Over	
FLAT SEAT CDC, CDCV, PL, PLV	2 - 5	0,138 - 0,345	-40	+40	$\pm 25\%$
	6 - 8	0,414 - 0,552	-40	+40	$\pm 20\%$
	9 - 12	0,612 - 0,827	-30	+30	$\pm 15\%$
	13 - 14	0,896 - 0,965	-10	+20	$\pm 10\%$
	15 - 19	1,03 - 1,31	-10	+20	± 2 psig (0,138 barg)
	20 - 40	1,38 - 2,76	-4	+14	± 2 psig (0,138 barg)
	41 - 50	2,83 - 3,45	-4	+14	$\pm 5\%$
	51 - 100	3,52 - 6,89	-4	+10	$\pm 5\%$
	101 - 500	6,96 - 34,5	-4	+7	$\pm 5\%$
	501 - up	34,6 - up	-3	+6	$\pm 5\%$

Notes for Table IV:

1. Special reduced manufacturing ranges can be obtained. 1/2, 3/4, or min/max ranges are available upon request. Please consult your Continental Disc Corporation representative or the factory for additional information.
2. Burst tolerances are the maximum expected variation from the rupture disc's rated (marked) burst pressure.

B.D.I.® Alarm System

In situations where it is important for immediate notification of pressure relief, Continental's patented B.D.I. (Burst Disc Indicator) Alarm System can be used. Compatible with the MICRO X and Composite (FS) rupture discs (as well as our other rupture disc designs), the Universal B.D.I. Alarm is composed of copper conductors adhered to a Teflon membrane and assembled between non-asbestos gaskets. As the rupture disc bursts, the alarm strip is severed, triggering an electrical signal which translates into audio and/or visual warning signals actuated through an alarm monitor. The Continental Disc B.D.I. Alarm Monitor is available with intrinsically safe outputs and computer compatibility.



Code Compliance

Continental Disc Corporation will provide rupture discs to national or international code requirements when specified by the customer.

C.D.C. will manufacture, temperature test and mark rupture discs in compliance with the requested code. Product may be supplied to ASME Section III or VIII, DIN, EN, BSI, JIS or other codes as required.

Continental Disc Corporation has been accredited and is authorized by the ASME Code to utilize the **UD** Code Symbol Stamp for product built in accordance with the requirements of the ASME Boiler and Pressure Vessel Code, Section VIII, Division 1.

The Composite Flat Seat Rupture Disc and MICRO X Rupture Disc flow performance was certified by The National Board of Boiler and Pressure Vessel Inspectors. These certified flow resistance values (K_R) and minimum net flow area values are available from Continental Disc Corporation or The National Board of Boiler and Pressure Vessel Inspectors.

Continental Disc Corporation maintains an ASME accepted flow laboratory to conduct flow testing for rupture discs, relief valves, and rupture disc/valve combinations.

* Burst Disc Indicator (B.D.I.) Alarm System incorporates United States patent no. Re. 34,308 and 4,408,194; Australia patent no. 539415; Canada patent no. 1199990; Germany patent no. 3174227.0; Japan patent no. 2032464; and Belgium, France, and United Kingdom patent no. EP 0 033 867.

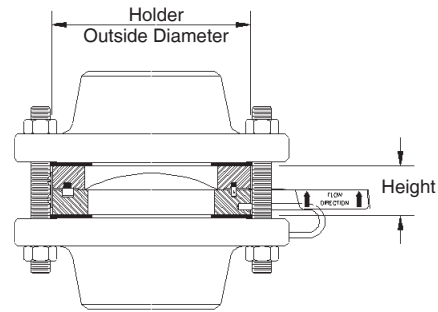

Table V - Unisert Holder Weights and Dimensions

RUPTURE DISC NOMINAL SIZE	ANSI		DIN		JIS		HEIGHT (inch / mm)	WEIGHT (lbs. / kgs)
	Class	Outside Diameter (inch / mm)	Class	Outside Diameter (mm)	Class	Outside Diameter (mm)		
1 in 25mm	150	2.50 / 63,5					1.75 / 44	1.7 / 0,8
	300 / 600	2.75 / 69,9	10 / 40	69,9	10 / 20	69,9	" "	2.5 / 1,1
					30 / 40	76,0	" "	2.7 / 1,2
	900 / 1500	3.00 / 76,2					2.25 / 57	3.5 / 1,6
			64 / 250	82,0			" "	4.2 / 1,9
	2500	3.25 / 82,6					2.75 / 70	5.5 / 2,5
1 1/2 in 40mm	150	3.25 / 82,6					1.75 / 44	2.7 / 1,2
					10 / 20	86,0	" "	3.0 / 1,4
	300 / 600	3.63 / 92,2	10 / 40	92,2			" "	3.7 / 1,7
	900 / 1500	3.75 / 95,3					2.50 / 64	5.8 / 2,6
			30 / 40	97,0			1.75 / 44	4.5 / 2,0
			64 / 160	102,0			2.50 / 64	6.9 / 3,0
			250	108,0			" "	8.5 / 3,8
	2500	4.50 / 114,3					3.50 / 89	13 / 5,9
					30/40	97,0	1.75 / 44	4.5 / 2,0
2 in 50mm	150	4.00 / 101,6			10 / 20	101,6	1.75 / 44	3.8 / 1,7
	300 / 600	4.25 / 108,0	10 / 40	108,0			" "	4.5 / 2,0
			64	111,0	30 / 40	111,0	" "	5.0 / 2,3
			100 / 160	118,0			3.00 / 76	10 / 4,5
			250	123,0			" "	12 / 5,4
	900 / 1500	5.50 / 139,7					" "	16 / 7,3
	2500	5.63 / 143,0					4.00 / 102	23 / 10
3 in 80mm	150	5.25 / 133,4			10	131,0	2.25 / 57	7.1 / 3,2
							" "	7.6 / 3,4
					16 / 20	137,0	" "	8.5 / 3,9
			10 / 40	142,0			" "	9.5 / 4,3
	300 / 600	5.75 / 146,1	64	146,1	30 / 40	146,1	" "	11 / 5,0
			100 / 160	153,0			3.00 / 76	16 / 7,3
	900	6.50 / 165,1					" "	20 / 9,1
			250	170,0			3.75 / 95	27 / 12
	1500	6.75 / 171,5				" "	28 / 13	
	2500	7.63 / 193,8					5.25 / 133	54 / 24
4 in 100mm					10	156,0	2.75 / 70	11 / 5,0
			10 / 16	162,0	16 / 20	162,0	" "	13 / 5,9
			25 / 40	168,0	30	168,0	" "	15 / 6,8
	150	6.75 / 171,5					" "	16 / 7,3
			64	173,0			3.00 / 76	50 / 23
	300	7.00 / 177,8			40	180,0	2.75 / 70	18 / 8,2
			100 / 160	180,0			3.50 / 89	64 / 29
	600	7.50 / 190,5					3.00 / 76	24 / 11
			250	202,0			4.25 / 108	99 / 45
	900	8.00 / 203,2					3.50 / 89	34 / 15
1500	8.13 / 206,5					4.25 / 108	43 / 20	
2500	9.13 / 231,9					6.00 / 152	85 / 39	

SPECIFICATIONS

Table V - Unisert Holder Weights and Dimensions (continued)

RUPTURE DISC NOMINAL SIZE	ANSI		DIN		JIS		HEIGHT	WEIGHT
	Class	Outside Diameter (inch / mm)	Class	Outside Diameter (mm)	Class	Outside Diameter (mm)	(inch / mm)	(lbs. / kgs)
6 in 150mm			10 / 16	217,0	10	217,0	3.75 / 95	26 / 12
	150	8.63 / 219,2					" "	26 / 12
			25 / 40	223,0			" "	29 / 13
					16 / 20	235,0	" "	36 / 16
			64	247,0			" "	44 / 20
	300	9.75 / 247,7			30	247,7	" "	44 / 20
			100 / 160	257,0			4.50 / 114	60 / 27
					40	262,0	3.75 / 95	54 / 24
	600	10.38 / 263,7					" "	55 / 25
	900	11.25 / 285,8					4.50 / 114	85 / 39
		250	284,0			6.50 / 165	120 / 54	
						6.50 / 165	144 / 52	
						8.50 / 216	211 / 96	
8 in 200mm			10 / 16	272,0	10	267,0	3.50 / 89	30 / 14
	150	10.88 / 276,4					3.13 / 80	29 / 13
					16 / 20	280,0	3.13 / 80	32 / 15
			25	283,0			3.63 / 92	42 / 19
			40	290,0			3.63 / 92	47 / 21
					30	293,0	3.63 / 92	49 / 22
	300	12.00 / 304,8					3.63 / 92	57 / 26
			64	309,0			4.56 / 116	77 / 35
					40	312,0	3.63 / 92	65 / 29
	600	12.50 / 317,5					4.38 / 111	84 / 38
		100 / 160	324,0			5.00 / 127	101 / 46	
						5.00 / 127	138 / 63	
		250	358,0			7.25 / 184	190 / 86	
						7.25 / 184	205 / 93	
						10.00 / 254	350 / 159	
10 in 250mm			10 / 16	327,0	10	330,0	2.50 / 64	35 / 16
	150	13.25 / 336,6					" "	37 / 17
			25	340,0			3.92 / 100	76 / 34
			40	352,0			" "	78 / 35
					16 / 20	353,0	2.50 / 64	41 / 19
	300	14.13 / 358,9			30	357,0	3.92 / 100	80 / 36
				40	377,0	" "	85 / 38	
12 in 300mm					5	367,0	2.63 / 67	48 / 22
			10	377,0	10	375,0	" "	50 / 23
			16	383,0			" "	53 / 24
			25	400,0			4.12 / 105	104 / 47
	150	16.00 / 406,4			16 / 20	403,0	2.63 / 67	59 / 27
	300	16.50 / 419,1	40	417,0	30	417,0	4.12 / 105	109 / 49
				40	431,0	4.12 / 105	113 / 51	

For sizes 1" through 8", the UNISERT Holder possesses another special feature. The height of the holder outlet is designed in a manner so that the dome of the rupture disc is protected during holder installation.

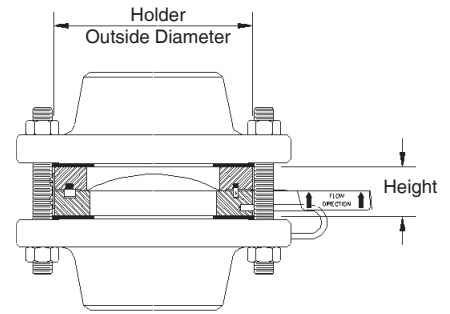

Table V - Unisert Holder Weights and Dimensions (continued)

RUPTURE DISC NOMINAL SIZE	ANSI		DIN		JIS		HEIGHT (inch / mm)	WEIGHT (lbs. / kgs)
	Class	Outside Diameter (inch / mm)	Class	Outside Diameter (mm)	Class	Outside Diameter (mm)		
14 in 350mm					5	410,0	2.25 / 57	35 / 16
					10	420,0	2.25 / 57	41 / 19
			10	437,0			2.25 / 57	52 / 24
			16	443,0			2.25 / 57	56 / 25
					16 / 20	447,8	2.25 / 57	59 / 27
	150	17.63 / 447,8					2.25 / 57	73 / 27
			25	457,0			4.25 / 108	125 / 57
			30	462,0			4.25 / 108	132 / 60
		40	474,0	40	474,0	4.25 / 108	148 / 67	
	300	19.00 / 482,6					4.25 / 108	160 / 73
16 in 400mm					5	470,0	3.00 / 76	62 / 28
					10	483,0	3.00 / 76	74 / 34
			10	488,0			3.00 / 76	79 / 36
			16	495,0			3.00 / 76	86 / 39
					16/20	507,0	3.00 / 76	98 / 44
	150	20.13 / 511,3					3.00 / 76	102 / 46
			25	514,0			4.50 / 114	159 / 72
			30	521,0			4.50 / 114	170 / 77
		40	531,0	40	531,0	4.50 / 114	186 / 84	
	300	21.13 / 511,3					4.50 / 114	195 / 88
			40	546,0			4.50 / 114	211 / 96
18 in 450mm					2 / 5	530,0	3.00 / 76	79 / 36
					10	538,0	3.00 / 76	87 / 39
	150	21.50 / 546,0					3.00 / 76	96 / 44
					16 / 20	572,0	3.00 / 76	125 / 57
	300	23.38 / 593,9					4.75 / 121	241 / 109
20 in 500mm					2 / 5	580,0	3.13 / 80	89 / 40
					10	593,0	3.13 / 80	105 / 48
	150	23.75 / 603,3	10	593,0			3.13 / 80	118 / 54
			16	617,0			3.13 / 80	135 / 61
					16 / 20	627,0	3.13 / 80	148 / 67
			25	624,0			5.13 / 130	240 / 109
			40	628,0			5.13 / 130	248 / 112
	300	25.63 / 651,0					5.13 / 130	299 / 136

For sizes 1" through 8", the UNISERT Holder possesses another special feature. The height of the holder outlet is designed in a manner so that the dome of the rupture disc is protected during holder installation.

SPECIFICATIONS

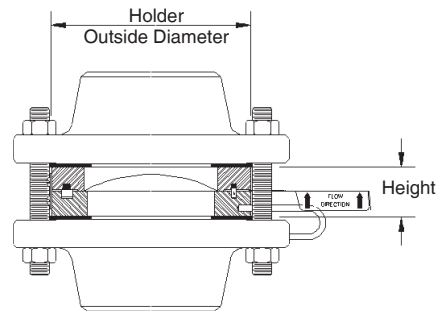

Table V - Unisert Holder Weights and Dimensions (continued)

RUPTURE DISC NOMINAL SIZE	ANSI		DIN		JIS		HEIGHT (inch / mm)	WEIGHT (lbs. / kgs)
	Class	Outside Diameter (inch / mm)	Class	Outside Diameter (mm)	Class	Outside Diameter (mm)		
24 in 600mm			6	678,0			3.25 / 83	106 / 48
					2 / 5	688,0	3.25 / 83	121 / 55
			10	695,0			3.25 / 83	131 / 59
					10	697,0	3.25 / 83	134 / 61
	150	28.13 / 714,5			16 / 20	731,0	3.25 / 83	161 / 73
			16	734,0			3.25 / 83	186 / 84
			25	731,0			5.00 / 127	290 / 132
		300	30.38 / 714,5			5.00 / 127	393 / 178	
28 in 700mm			6	783,0			4.00 / 102	164 / 74
					2 / 5	793,0	4.00 / 102	183 / 83
			16	804,0			4.00 / 102	206 / 93
			10	810,0	10	807,0	4.00 / 102	213 / 97
	150	32.63 / 828,8					4.00 / 102	219 / 99
					16	833,0	4.00 / 102	260 / 118
30 in 750mm					20	852,0	4.00 / 102	269 / 122
					2 / 5	847,0	4.00 / 102	201 / 91
					10	867,0	4.00 / 102	246 / 112
	150	34.63 / 879,6					4.00 / 102	275 / 125
					16	893,0	4.00 / 102	307 / 139
32 in 800mm					20	914,0	4.00 / 102	356 / 161
			6	890,0			4.00 / 102	196 / 89
					2 / 5	897,0	4.00 / 102	212 / 96
			16	911,0			4.00 / 102	246 / 112
			10	917,0	10	917,0	4.00 / 102	260 / 118
	150	36.88 / 936,8					4.00 / 102	308 / 140
36 in 900mm					16	942,0	4.00 / 102	321 / 146
					20	974,0	4.00 / 102	402 / 182
			6	990,0			4.00 / 102	215 / 98
					2 / 5	997,0	4.00 / 102	233 / 106
			16	1011,0			4.00 / 102	269 / 122
			10	1017,0	10	1017,0	4.00 / 102	286 / 130
36 in 900mm	150	41.00 / 1041,4					4.00 / 102	352 / 160
					16	1042,0	4.00 / 102	353 / 160
					20	1084,0	4.00 / 102	471 / 214

For sizes 1" through 8", the UNISERT holder possesses another special feature. The height of the holder outlet is designed in a manner so that the dome of the rupture disc is protected during holder installation.

HOW TO ORDER

To facilitate manufacturing and shipping of your UNISERT Rupture Disc Assembly, the following information should be supplied when ordering. For more specific information regarding applicable rupture disc and B.D.I. Alarm System information, consult Continental Disc Bulletin No. 5-7701-5, the C.D.C. price list, your Continental Disc Representative, or the factory.

HOLDER SPECIFICATIONS

1. Quantity _____
2. Size _____
3. Bolting class (ANSI, DIN, JIS)
4. Material (inlet, outlet)
5. Options: gasket facing, gauge tap, coatings
6. Accessories: nipple/tee, excess flow valve, pressure gauge, studs and nuts, eyebolts, jackscrews

SPECIFICATIONS

1. Quantity _____
2. Size _____
3. Type _____
4. Options: linings, coatings, rings, gaskets, or vacuum support
5. Materials _____
6. Specified pressure _____
7. Specified temperature _____
8. Manufacturing range: Standard, 1/2, 3/4 or min/max _____
9. Previous manufacturing number (when reordering) _____
10. ASME or other Code Requirements _____

QUALITY ASSURANCE / DOCUMENTATION

1. ASME Code tests _____
2. Special cleaning _____
3. Special packaging _____
4. Special tagging _____
5. Temperature testing _____
6. Material test reports _____
7. Other _____

OPERATING SPECIFICATIONS

1. Maximum allowable working pressure (vessel M.A.W.P.) _____
2. Operating pressure _____
3. Operating temperature _____
4. Vacuum/backpressure _____
5. Cycle conditions _____
6. Minimum net flow area required _____
7. Media (compressible or incompressible) _____
8. Use under relief valves (requires non-fragmenting design) _____

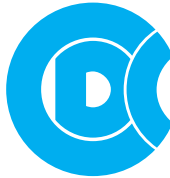

**Continental Disc[®]
Corporation**

Performance Under Pressure[®]

A Siegel-Robert Company



Certified Quality System
First Certified In 1992



ASME Code Symbol Stamp
Available When Specified



China Manufacture License
Available When Specified



Pressure Equipment Directive
Available When Specified

Continental Disc Corporation has representatives located throughout the world.
Contact the C.D.C. office nearest you for the authorized representative in your area.

CORPORATE HEADQUARTERS

Continental Disc Corporation
3160 W. Heartland Drive
Liberty, Missouri 64068-3385 USA

Phone: (816) 792-1500
FAX: (816) 792-2277 / 5447
E-mail: pressure@contdisc.com
Website: www.contdisc.com

THE NETHERLANDS

Continental Disc Corporation
Energieweg 20
2382 NJ Zoeterwoude-Rijndijk
The Netherlands

Phone: + (31) 71-5412221
FAX: + (31) 71-5414361
E-mail: cdcnl@contdisc.com

GERMANY

Continental Disc
Deutschland GmbH
Virmondstrasse 151
47877 Willich
Germany

Phone: + (49) 2156-490802
FAX: + (49) 2156-492547
E-mail: cdd@contdisc.com

UNITED KINGDOM

Continental Disc UK Ltd.
Unit C, The Business Centre
Faringdon Avenue,
Harold Hill, Romford
Essex RM3 8EN
United Kingdom

Phone: + (44) 1708-386444
FAX: + (44) 1708-386486
E-mail: cduk@contdisc.com

CHINA

Continental Disc Corporation
2026 The Executive Center
20/F The Center
989 Changle Rd.
Shanghai, 200031
P.R. China

Phone: + (86) 21-5117-5848
Fax: + (86) 21-5117-5849
Mobile: + (86) 137-8897-2291
E-mail: jyang@contdisc.com

DUBAI

Continental Disc Corporation
P.O. Box 2234
Dubai, U.A.E.

Phone: + (971) 43214490
FAX: + (971) 43438840
Mobile: + (971) 508129525
E-mail: kannan@contdisc.com

Continental Disc Corporation reserves the right to alter the information in this publication without notice.

Printed in U.S.A.

Reproduction without written permission prohibited.

© 1991 - 2005 Continental Disc Corporation

06072000BP