



**Continental Disc®  
Corporation**

# Preparation and Installation of the Scored MICRO X<sup>®</sup> Rupture Disc / UNISERT<sup>®</sup> or RHI Insert Holder Assembly

GEP-6008  
Rev. L 21398  
Ref. I.D.: 5468

## **WARNING**

USER SHOULD READ AND THOROUGHLY UNDERSTAND THESE INSTRUCTIONS BEFORE INSTALLING RUPTURE DISC. THESE INSTRUCTIONS DO NOT PURPORT TO ADDRESS ALL OF THE SAFETY FACTORS ASSOCIATED WITH THE RUPTURE DISC'S USE IN SERVICE. IT IS THE RESPONSIBILITY OF THE USER TO ESTABLISH APPROPRIATE SAFETY, HEALTH, AND TRAINING MEASURES FOR THEIR PERSONNEL INSTALLING, SERVICING, OR WORKING IN AN AREA WHERE RUPTURE DISC ASSEMBLIES ARE IN USE. SERVICE AND/OR MAINTENANCE ON OR AROUND THE RUPTURE DISC DEVICE MUST NOT BE PERFORMED WHILE THE DEVICE IS SUBJECTED TO OPERATING PRESSURES AND/OR TEMPERATURES.

IT IS THE USER'S SOLE RESPONSIBILITY FOR DESIGN AND PLACEMENT OF RUPTURE DISCS WITHIN THEIR FACILITY AND UPON THE EQUIPMENT UPON WHICH THE RUPTURE DISC OF USER'S SELECTION IS TO BE LOCATED. IT IS USER'S SOLE RESPONSIBILITY FOR THE DESIGN OF ADEQUATE VENTING AND INSTALLATION OF ADEQUATE VENT PIPING OR DIRECTIONAL FLOW AFTER RUPTURE OCCURS WITH THE RUPTURE DISC AS INTENDED. WHEN SIZE IS SPECIFIED, CONTINENTAL DISC CORPORATION ASSUMES THAT ADEQUATE PROVISIONS HAVE BEEN MADE BY PURCHASER FOR PROPER VENTING OF A SYSTEM TO RELIEVE THE SPECIFIC PRESSURE. LOCATE RUPTURE DISC WHERE PEOPLE OR PROPERTY WILL NOT BE EXPOSED TO THE SYSTEM DISCHARGE IN CASE OF RUPTURE. VENT TOXIC OR FLAMMABLE FUMES OR LIQUIDS TO A SAFE LOCATION TO PREVENT PERSONAL INJURY OR PROPERTY DAMAGE.

IT IS THE USER'S SOLE RESPONSIBILITY TO SPECIFY THE BURST PRESSURE RATING OF A RUPTURE DISC AT A COINCIDENT TEMPERATURE AT WHICH THE RUPTURE DISC IS TO BE USED. A RUPTURE DISC IS A TEMPERATURE SENSITIVE DEVICE. THE BURST PRESSURE OF THE RUPTURE DISC IS DIRECTLY AFFECTED BY ITS EXPOSURE TO THE COINCIDENT TEMPERATURE. GENERALLY, AS THE TEMPERATURE AT THE RUPTURE DISC INCREASES, THE BURST PRESSURE DECREASES; INVERSELY, AS THE TEMPERATURE AT THE RUPTURE DISC DECREASES, THE BURST PRESSURE MAY INCREASE. FAILURE TO PROPERLY UTILIZE A RUPTURE DISC AT THE SPECIFIED COINCIDENT TEMPERATURE COULD CAUSE PREMATURE FAILURE OR OVERPRESSURIZATION OF A SYSTEM.

THE INSTANTANEOUS RELEASE OF PRESSURE FROM THE RUPTURE DISC CAN CREATE VIOLENT NOISES DUE TO THE DISCHARGE AT SONIC VELOCITY. IT IS THE USER'S SOLE RESPONSIBILITY TO PROTECT AGAINST HEARING DAMAGE TO ANY BYSTANDERS.

RUPTURE DISCS AND TAGS ARE MADE OF METAL FOILS OF VARYING THICKNESS. THE METAL EDGES MAY BE SHARP. PERSONNEL INSTALLING OR EXAMINING THE RUPTURE DISCS SHOULD PROTECT AGAINST CUTS OR INJURY WHEN HANDLING THE RUPTURE DISC. DO NOT LIFT A RUPTURE DISC BY ITS ATTACHED TAG.

PARTICLES MAY BE DISCHARGED WHEN THE RUPTURE DISC RUPTURES. THESE PARTICLES MAY BE PART OF THE RUPTURE DISC ITSELF, OR OTHER ENVIRONMENTAL MATTER IN THE SYSTEM. IT IS THE USER'S SOLE RESPONSIBILITY TO ASSURE THAT THESE PARTICLES ARE DIRECTED TO A SAFE AREA TO PREVENT PERSONAL INJURY OR PROPERTY DAMAGE.

THERE IS NO GUARANTEE OF RUPTURE DISC LIFE. SUCH LIFE SPAN IS AFFECTED BY CORROSION, CREEP AND FATIGUE, AND PHYSICAL DAMAGE. THESE CONDITIONS WILL DERATE THE RUPTURE DISC TO A LOWER SET PRESSURE. THE CUSTOMER AND/OR USER SHOULD BE PREPARED TO HANDLE PREMATURE FAILURE OF THE RUPTURE DISC. THE MEDIA OR OTHER ENVIRONMENTAL CONDITIONS SHOULD NOT ALLOW ANY BUILDUP OR SOLIDIFICATION OF MEDIA TO OCCUR ON A RUPTURE DISC. THIS MAY INCREASE THE PRESSURE SETTING OF THE RUPTURE DISC.

CUSTOMER AND/OR ITS INSTALLER SHALL BE SOLELY RESPONSIBLE FOR THE PROPER INSTALLATION OF SELLER'S HOLDERS AND RUPTURE DISCS INTO A SYSTEM. CUSTOMER AND/OR ITS INSTALLER SHALL BE SOLELY RESPONSIBLE FOR IMPROPER INSTALLATION AND PHYSICAL DAMAGE RESULTING THEREFROM, INCLUDING BUT NOT LIMITED TO, DAMAGE RESULTING FROM LEAKAGE, IMPROPER TORQUING OR SEATING OF A RUPTURE DISC OR FAILURE TO FOLLOW INSTALLATION INSTRUCTIONS WHERE PROVIDED.

RUPTURE DISCS ARE PRECISION SAFETY DEVICES AND MUST BE INSTALLED PROPERLY. RUPTURE DISCS MUST BE INSTALLED BY TRAINED, KNOWLEDGEABLE INSTALLERS AND ONLY WITHIN ENVIRONMENTS SUITABLE AND APPROPRIATE FOR A RUPTURE DISC. CARE MUST BE USED IN A FACILITY'S DESIGN TO PROTECT BOTH THE RUPTURE DISC FROM INADVERTENT DAMAGE WHICH COULD CAUSE ITS PREMATURE RELEASE AND TO PROTECT INDIVIDUALS EXPOSED TO HAZARDS CREATED BY SUCH SUDDEN RELEASE.

PROPER INSTALLATION OF A RUPTURE DISC IS CRITICAL TO PERFORMANCE AND TO SAFETY. FAILURE TO PROVIDE PROPER SEATING OF A RUPTURE DISC MAY AFFECT RUPTURE DISC PERFORMANCE, BURST PRESSURE ACCURACY AND MAY RESULT IN ITS PREMATURE FAILURE.

## I. Safety Precautions Before Installation

1. The MICRO X rupture disc is a precision instrument and must be handled with extreme care. Rupture discs should be installed only by qualified personnel familiar with rupture discs and proper piping practices.
2. The score on the convex side of the rupture disc is a factory installed precision score. Do not install rupture disc if there is any damage in the dome area. A damaged rupture disc is any rupture disc with visible nicks or dents in the dome.
3. Continental Disc Corporation does not recommend reinstalling a rupture disc that has been removed from the holder as reinstallation may adversely affect the joint sealing capabilities and/or performance of the rupture disc.

## II. Preparation of Holders for Installation

### New Installation

Clean all foreign material from the rupture disc sealing area of both the holder inlet and outlet.

### Replacement Installation

1. If the Burst Disc Indicator (B.D.I.<sup>®</sup>) Alarm System is used, disconnect the alarm strip from the monitor by unplugging the B.D.I. connector from the lead wire connector.
2. Remove the holder from the system and place on a flat surface.
3. Disassemble the holder by loosening the pre-assembly screws, or by removing the pre-assembly cap screws on the holder outlet. Lift the holder outlet up and set aside; then remove the burst rupture disc.
4. Clean the rupture disc sealing area of both the holder inlet and outlet. These surfaces must be completely clean and free of all rust, corrosion, and foreign material to ensure a proper seal. Use of solvents, steel wool, or fine emery cloth is permissible. Do not re-machine. Do not use scraper or abrasives.
5. Inspect the rupture disc sealing area for nicks, scratches, or pitting. If any of these conditions are present, consult the factory for repair.
6. Remove any adhered gasket material from previous installation.

## III. Assembly of the Rupture Disc and Holder

Component parts of the holder assembly are illustrated in the proper installation sequence.

### SIZES 1" THROUGH 12" (See Figure A)

1. Carefully remove and discard any shipping protectors furnished with rupture discs or holder. **DO NOT INSTALL A SHIPPING PROTECTOR IN A HOLDER ASSEMBLY.**
2. Place the holder outlet on a flat surface with the alignment pins pointing up. Sizes 4", 6", and 8" RHI holder outlets, and 10" and 12" UNISERT holder outlets must be elevated from the work surface approximately 1" to avoid damage to the rupture disc dome during assembly. NOTE: Alignment pin arrangement will vary depending on size.
3. Match the notches in the rupture disc with the shape of the pins. Place the rupture disc over the pins with the dome side down. The rupture disc tag will be face down.
4. Match the holes in the holder inlet with the shape of the pins in the holder outlet. Position the holder inlet carefully onto the alignment pins as shown, ensuring that the rupture disc is not damaged.
5. Fasten the assembly together by tightening the pre-assembly screws or by replacing and tightening the pre-assembly cap screws.
6. Invert assembled rupture disc and holder. Check all flow arrows for proper flow direction.

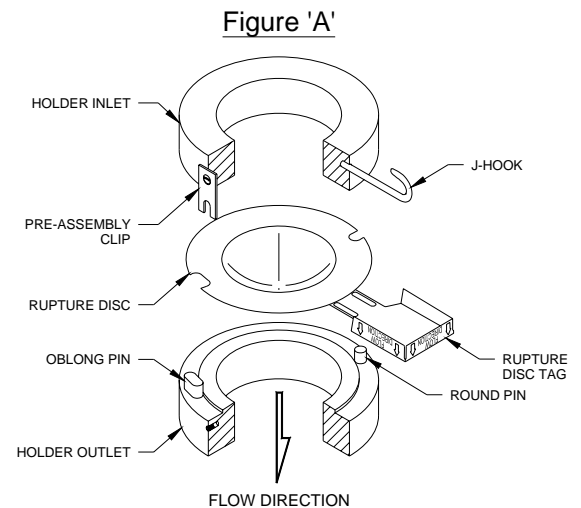

## SIZES 14" THROUGH 36" (See Figure B)

1. Carefully remove and discard any shipping protectors furnished with rupture discs or holder. **DO NOT INSTALL A SHIPPING PROTECTOR IN A HOLDER ASSEMBLY.**
2. Place the holder inlet on a flat surface.
3. Place the MICRO X rupture disc on the holder inlet opening with the dome facing up as illustrated.
4. Align and lower the holder outlet carefully onto the holder inlet.
5. Fasten the assembly together by installing and tightening the pre-assembly cap screws.

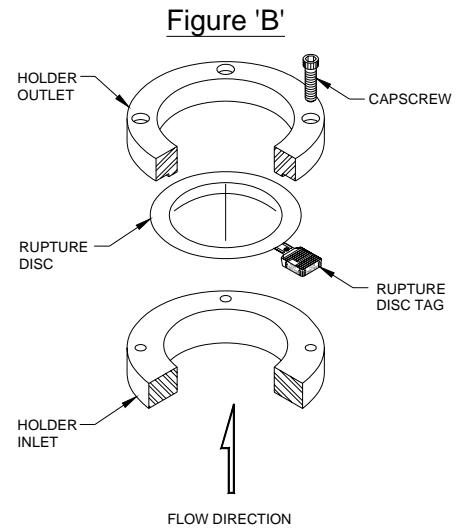

## IV. Installation of the Holder Assembly Into the System (See Figure C)

1. If the B.D.I. Alarm System is to be used, see the Universal B.D.I. Assembly installation instructions for additional details.
2. Before placing the assembly into the system, ensure that the companion flange gasket surfaces are clean and free of all rust, corrosion, and foreign material.
3. On sizes 1" through 12" a J-Hook is provided on the holder inlet to ensure correct installation of the assembly relative to flow direction. Prior to installation of the assembly, the corresponding inlet companion flange must be drilled to accommodate the J-Hook. Refer to the J-Hook Installation Guide for locating and drilling specifications.
4. Install the holder assembly and customer furnished gaskets **WITH ALL FLOW ARROWS POINTING IN THE PROPER FLOW DIRECTION** and the J-Hook (if applicable) inserted into the drilled companion flange.
5. Install lightly oiled free running studs and nuts to finger tightness. Using a cross torquing pattern (see Figure D), torque each nut with a calibrated torque wrench at 20% increments of recommended torque value (see Table 1). Repeat 20% increments and cross torquing pattern until final torque value is achieved. Recheck all nuts in rotational sequence at final torque value. These values are based on using gasket materials having a gasket factor of 2.75, gasket seating stress of 3,700 psi, and stud and nut material per ASME SA193-B7 and SA194-2H respectively, with a stress of up to 30,000 psi. The use of studs and nuts with lower strength may prove unsatisfactory.

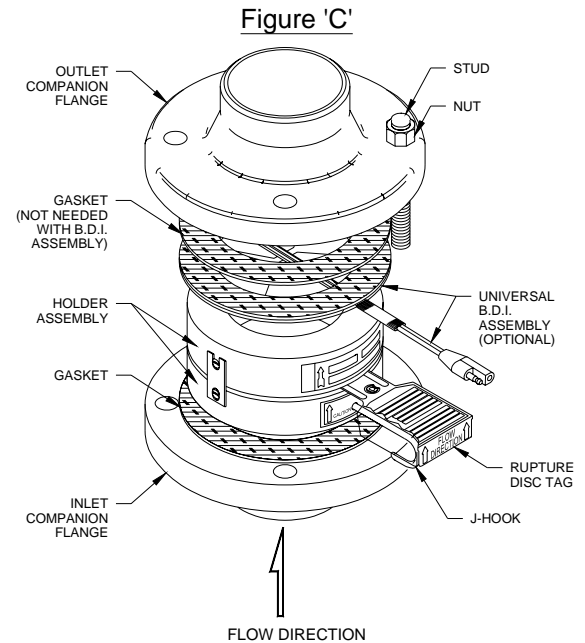

## V. Preventative Maintenance

1. Risk assessment and an annual rupture disc replacement are recommended. Rupture disc service life is determined by system operating conditions. The effects of severe pressure/vacuum cycles, corrosion, temperature variations, or other adverse conditions must be evaluated by the user through actual service experience to determine optimal service life.
2. **IF THE RUPTURE DISC IS NOT REPLACED PERIODICALLY WHEN EXPOSED TO THESE CONDITIONS, PREMATURE FAILURE OF THE RUPTURE DISC MAY OCCUR, THEREBY DISCHARGING THE PROCESS MEDIA.**
3. To avoid extended downtime, maintain three spare rupture discs in stock at all times for each holder in use. The number of spares required ultimately will be determined by service conditions.

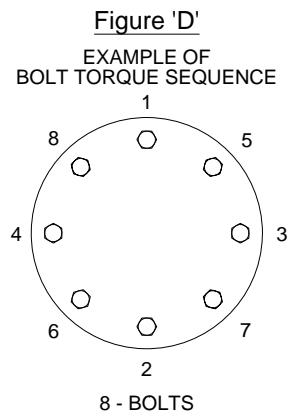

## VI. Customer Service

If you wish to discuss your application, installation, or maintenance, please contact the Customer Service Department at one of the addresses shown on the last page of these instructions.

Burst Disc Indicator (B.D.I.) Alarm System incorporates U.S. patent no. Re. 34,308 and 4,408,194; Australia patent no. 539415; Germany patent no. 3174227.0; Belgium, France and United Kingdom patent no. EP 0 033 867; Canada patent no. 1199990; Japan patent no. 2032464.

### B.D.I. ALARM SYSTEM OPERATING LIMITS

TEMPERATURE: -40° F to + 400° F  
(-40° C to + 204° C)

MAX CURRENT: 50 Milli Amps  
MAX VOLTAGE: 24 VDC RMS

BURST DISC INDICATOR (B.D.I.®): Sizes 25mm through 900mm (1 inch through 36 inches)

Marked:  II 2 G D EEx ia IIC  
(Tamb = -40° C to +204° C)

EC Type Examination Certificate: ITSO3ATEX 21357U

FULFILLS THE REQUIREMENTS OF DIRECTIVE 94/9/EC (ATEX) FOR: COMPONENTS of equipment and protective systems intended for use in potentially explosive atmospheres.

APPLIED HARMONIZED STANDARD: EN 50 014: 1997 + Amds 1 & 2 General Requirements  
EN 50 020: 2002, Intrinsic Safety

ADDITIONAL INFORMATION: Conformity assessment performed by Notified Body no. 0359,  
ITS Testing and Certification Limited, Leatherhead, Surrey, UK.

**TABLE 1**  
**Recommended Torque Values for Scored MICRO X**  
**Rupture Discs Sizes 1" Through 36"**

SIZE		COMPANION FLANGE RATING			RECOMMENDED TORQUE VALUE		SIZE		COMPANION FLANGE RATING			RECOMMENDED TORQUE VALUE			
IN	MM	ANSI	DIN	JIS	FT•LB	N•m	IN	MM	ANSI	DIN	JIS	FT•LB	N•m		
1	25	150	---	---	35	47	2	50	---	64	---	164	222		
		---	10/16	---	33	45			---	100	---	197	267		
		---	---	10/16/20	44	60			900/1500	---	---	160	217		
		300/600	---	---	65	88			---	160	---	367	498		
		---	25/40	---	49	66			---	250	---	184	249		
		---	64/100	30/40	66	89			2500	---	---	170	230		
		900/1500	---	---	180	244			3	80	150	---	---	65	88
		---	160	---	130	176					---	10/16	10	33	45
		---	250	---	162	220					---	---	16/20	41	56
		2500	---	---	100	136					300/600	---	---	120	163
1-1/2	40	150	---	---	35	47	---	25/40	---	101	137				
		---	10/16	10/16/20	44	60	---	---	30/40	126	171				
		300/600	---	---	120	163	---	64	---	126	171				
		---	25/40	---	101	137	---	100	---	151	205				
		---	64/100	30/40	126	171	900	---	---	180	244				
		900/1500	---	---	250	339	---	160	---	194	263				
		---	160	---	197	267	1500	---	---	255	346				
		---	250	---	236	320	---	250	---	241	327				
		2500	---	---	285	386	4	100	150	---	---	65	88		
		2	50	150	---	---			65	88	---	10/16	10	66	89
---	10/16			10	66	89			---	---	16/20	82	111		
---	---			16/20	33	45			300	---	---	120	163		
300/600	---			---	65	88			---	25/40	---	126	171		
---	25/40			---	131	178			---	---	30	139	188		
---	---			30/40	66	89	600	---	---	185	251				

**TABLE 1**  
**Recommended Torque Values for Scored MICRO X**  
**Rupture Discs Sizes 1" Through 36"**

SIZE		COMPANION FLANGE RATING			RECOMMENDED TORQUE VALUE		SIZE		COMPANION FLANGE RATING			RECOMMENDED TORQUE VALUE			
IN	MM	ANSI	DIN	JIS	FT•LB	N•m	IN	MM	ANSI	DIN	JIS	FT•LB	N•m		
4	100	---	---	40	178	241	8	200	---	64/100	---	473	641		
		---	64	---	200	271			900	---	---	505	685		
		---	100	---	225	305			---	160	---	477	647		
		900	---	---	350	475			1500	---	---	595	807		
		---	160	---	331	449			---	250	---	562	762		
		1500	---	---	390	529			2500	---	---	735	997		
		---	250	---	368	449			10	250	150	---	---	185	251
		2500	---	---	465	631					---	10	---	166	225
6	150	150	---	---	120	163	---	---			10	183	248		
		---	10/16	10	126	171	---	16			16/20	200	271		
		---	---	16/20	92	125	300	---			---	275	373		
		300	---	---	120	163	---	25			---	390	529		
		---	25/40	---	227	308	---	40			30	433	587		
		---	---	30	151	205	600	---			---	435	590		
		600	---	---	275	373	---	100	---	657	891				
		---	---	40	260	352	900	---	---	475	644				
		---	64	---	487	660	---	160	---	712	965				
		---	100	---	325	441	12	300	150	---	---	185	251		
		900	---	---	325	441			---	10	---	166	225		
		---	160	---	341	462			---	---	10	137	186		
		1500	---	---	395	536			---	16	---	200	271		
		---	250	---	373	506			---	---	16/20	150	203		
		2500	---	---	860	1166			300	---	---	375	508		
		8	200	150	10	---			130	176	---	25	---	354	480
---	16			10	91	123			---	---	30	394	534		
---	---			16/20	100	136	600	---	---	395	536				
300	---			---	180	244	---	100	---	606	822				
---	25			30	194	263	900	---	---	430	583				
---	40			---	219	297	---	160	---	600	813				
600	---			---	410	556									

SIZE		DISC RATING	COMPANION FLANGE RATING				RECOMMENDED TORQUE VALUE	
IN	MM	(PSIG)	ANSI	MSS-SP44	DIN	JIS	FT•LB	N•m
14	350	up to 100	150	---	---	---	220	298
		up to 100	---	---	10	---	130	176
		up to 100	---	---	---	10	143	194
		up to 100	---	---	16	---	156	211
		up to 100	---	---	---	16/20	195	264
		100 to 275	150	---	---	---	275	373
		100 to 275	---	---	10	---	162	220
		100 to 275	---	---	---	10	179	243
		100 to 275	---	---	16	---	195	264
		100 to 275	---	---	---	16/20	244	331
		up to 350	300	---	---	---	---	375

**TABLE 1**  
**Recommended Torque Values for Scored MICRO X**  
**Rupture Discs Sizes 1" Through 36"**

SIZE		DISC RATING (PSIG)	COMPANION FLANGE RATING				RECOMMENDED TORQUE VALUE		
IN	MM		ANSI	MSS-SP44	DIN	JIS	FT•LB	N•m	
14	350	up to 350	---	---	25	30	492	667	
		up to 350	---	---	40	---	541	733	
16	400	up to 100	150	---	---	---	220	298	
		up to 100	---	---	10	10	208	282	
		up to 100	---	---	16	---	234	317	
		up to 100	---	---	---	16/20	260	352	
		100 to 275	150	---	---	---	275	375	
		100 to 275	---	---	10	10	260	352	
		100 to 275	---	---	16	---	292	396	
		100 to 275	---	---	---	16/20	325	441	
		up to 350	300	---	---	---	---	485	658
		up to 350	---	---	---	25	---	630	854
		up to 350	---	---	---	---	30	461	625
up to 350	---	---	---	40	---	687	931		
18	450	up to 100	150	---	---	---	300	407	
		up to 100	---	---	---	10	202	274	
		up to 100	---	---	---	16/20	252	342	
		100 to 275	150	---	---	---	375	508	
		100 to 275	---	---	---	10	315	427	
		100 to 275	---	---	---	16/20	394	534	
20	500	up to 100	150	---	---	---	300	407	
		up to 100	---	---	10	10	252	342	
		up to 100	---	---	16	16/20	315	427	
		100 to 275	150	---	---	---	375	508	
		100 to 275	---	---	10	10	394	534	
		100 to 275	---	---	16	16/20	492	667	
24	600	up to 100	150	---	---	---	425	576	
		up to 100	---	---	10	---	361	489	
		up to 100	---	---	---	10	335	454	
		up to 100	---	---	16	---	442	599	
		up to 100	---	---	---	16/20	401	544	
		100 to 275	150	---	---	---	485	658	
		100 to 275	---	---	10	---	516	700	
		100 to 275	---	---	---	10	573	776	
		100 to 275	---	---	16	---	630	854	
		100 to 275	---	---	---	16/20	687	931	
28	700	up to 75	---	150	---	---	375	508	
		up to 75	---	---	10	---	372	504	
		up to 75	---	---	---	10	413	560	
		up to 75	---	---	16	---	455	617	
		up to 75	---	---	---	16	537	728	
		up to 75	---	---	---	20	620	841	
		75 to 275	---	150	---	---	485	658	
		75 to 275	---	---	10	---	481	652	

**TABLE 1**  
**Recommended Torque Values for Scored MICRO X**  
**Rupture Discs Sizes 1" Through 36"**

SIZE		DISC RATING (PSIG)	COMPANION FLANGE RATING				RECOMMENDED TORQUE VALUE	
IN	MM		ANSI	MSS-SP44	DIN	JIS	FT•LB	N•m
28	700	75 to 275	---	---	---	10	535	725
		75 to 275	---	---	16	---	588	797
		75 to 275	---	---	---	16	695	942
		75 to 275	---	---	---	20	802	1087
30	750	up to 75	---	150	---	---	395	536
		up to 75	---	---	---	10	435	590
		up to 75	---	---	---	16	566	767
		up to 75	---	---	---	20	755	1024
		75 to 275	---	150	---	---	485	658
		75 to 275	---	---	---	10	535	725
		75 to 275	---	---	---	16	695	942
		75 to 275	---	---	---	20	927	1257
32	800	up to 75	---	150	---	---	640	868
		up to 75	---	---	10	---	588	797
		up to 75	---	---	---	10	504	683
		up to 75	---	---	16	---	705	956
		up to 75	---	---	---	16	882	1196
		up to 75	---	---	---	20	1019	1382
		75 to 275	---	150	---	---	875	1186
		75 to 275	---	---	10	---	804	1090
		75 to 275	---	---	---	10	689	934
		75 to 275	---	---	16	---	964	1307
		75 to 275	---	---	---	16	1205	1634
		75 to 275	---	---	---	20	1393	1889
36	900	up to 75	---	150	---	---	665	902
		up to 75	---	---	10	10	598	811
		up to 75	---	---	16	---	838	1136
		up to 75	---	---	---	16	1047	1419
		up to 75	---	---	---	20	1210	1640
		75 to 275	---	150	---	---	875	1186
		75 to 275	---	---	10	10	787	1067
		75 to 275	---	---	16	---	945	1281
		75 to 275	---	---	---	16	1181	1601
		75 to 275	---	---	---	20	1365	1851

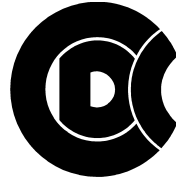

**Continental Disc<sup>®</sup>  
Corporation**

**Performance Under Pressure<sup>®</sup>**

A Siegel-Robert Company



**Certified Quality System**  
First Certified In 1992



**ASME Code Symbol Stamp**  
If stamped, this product is built in accordance with the requirements of the ASME Boiler and Pressure Vessel Code, Section VIII, Division 1.



**China Manufacture License Type Approval Stamp**  
If stamped, this product is in full compliance with the provisions of the Peoples Republic of China Import Regulations for Boiler and Pressure Vessel safety devices.



**3A Sanitary Standards Stamp**  
If stamped, this product is in full compliance with the 3A standards, Serial #60-00, of the International Association of Milk, Food, and Environmental Sanitarians, Inc.



**European Union CE Mark Type Approval Stamp**  
If stamped, this product is certified to conform to the essential requirements of the Pressure Equipment Directive.

Continental Disc Corporation has representatives located throughout the world.  
Contact the C.D.C. office nearest you for the authorized representative in your area.

### CORPORATE HEADQUARTERS

Continental Disc Corporation  
3160 W. Heartland Drive  
Liberty, Missouri 64068-3385 USA  
Phone: (816) 792-1500  
FAX: (816) 792-2277 / 5447  
E-mail: [pressure@contdisc.com](mailto:pressure@contdisc.com)  
Website: [www.contdisc.com](http://www.contdisc.com)

#### THE NETHERLANDS

Continental Disc Corporation  
Energieweg 20  
2382 NJ Zoeterwoude-Rijndijk  
The Netherlands  
Phone: +(31) 71-5412221  
Fax: +(31) 71-5414361  
E-mail: [cdcnl@contdisc.com](mailto:cdcnl@contdisc.com)

#### GERMANY

Continental Disc Deutschland GmbH  
Virmondstrasse 151  
47877 Willich  
Germany  
Phone: +(49) 2156-490802  
Fax: +(49) 2156-492547  
E-mail: [cdd@contdisc.com](mailto:cdd@contdisc.com)

#### UNITED KINGDOM

Continental Disc UK Ltd.  
Unit C, The Business Centre  
Faringdon Avenue, Harold Hill,  
Romford  
Essex RM3 8EN  
United Kingdom  
Phone: +(44) 1708-386444  
Fax: +(44) 1708-386486  
E-mail: [cduk@contdisc.com](mailto:cduk@contdisc.com)

#### CHINA

Continental Disc Corporation  
2026 The Executive Center  
20/F The Center  
989 Changle Rd.  
Shanghai, 200031  
P.R. China  
Phone: +(86) 21-5117-5848  
Fax: +(86) 21-5117-5849  
Mobile: +(86) 137-8897-2291  
E-mail: [jyang@contdisc.com](mailto:jyang@contdisc.com)

#### DUBAI

Continental Disc Corporation  
P. O. Box 2234  
Dubai, U.A.E.  
Phone: +(971) 43214490  
Fax: +(971) 43438840  
Mobile: +(971) 508129525  
E-mail: [kannani@contdisc.com](mailto:kannani@contdisc.com)

Continental Disc Corporation reserves the right to alter the information in this publication without notice.

Reproduction without written permission prohibited.

© 1999, 2001, 2003, 2004, 2008 Continental Disc Corporation

Printed in U.S.A.