



**Continental Disc®
Corporation**

Preparation and Installation of the KBA Rupture Disc Assembly

WARNING

USER SHOULD READ AND THOROUGHLY UNDERSTAND THESE INSTRUCTIONS BEFORE INSTALLING RUPTURE DISC. THESE INSTRUCTIONS DO NOT PURPORT TO ADDRESS ALL OF THE SAFETY FACTORS ASSOCIATED WITH THE RUPTURE DISC'S USE IN SERVICE. IT IS THE RESPONSIBILITY OF THE USER TO ESTABLISH APPROPRIATE SAFETY, HEALTH, AND TRAINING MEASURES FOR THEIR PERSONNEL INSTALLING, SERVICING, OR WORKING IN AN AREA WHERE RUPTURE DISC ASSEMBLIES ARE IN USE. SERVICE AND/OR MAINTENANCE ON OR AROUND THE RUPTURE DISC DEVICE MUST NOT BE PERFORMED WHILE THE DEVICE IS SUBJECTED TO OPERATING PRESSURES AND/OR TEMPERATURES.

IT IS THE USER'S SOLE RESPONSIBILITY FOR DESIGN AND PLACEMENT OF RUPTURE DISCS WITHIN THEIR FACILITY AND UPON THE EQUIPMENT UPON WHICH THE RUPTURE DISC OF USER'S SELECTION IS TO BE LOCATED. IT IS USER'S SOLE RESPONSIBILITY FOR THE DESIGN OF ADEQUATE VENTING AND INSTALLATION OF ADEQUATE VENT PIPING OR DIRECTIONAL FLOW AFTER RUPTURE OCCURS WITH THE RUPTURE DISC AS INTENDED. WHEN SIZE IS SPECIFIED, CONTINENTAL DISC CORPORATION ASSUMES THAT ADEQUATE PROVISIONS HAVE BEEN MADE BY PURCHASER FOR PROPER VENTING OF A SYSTEM TO RELIEVE THE SPECIFIC PRESSURE. LOCATE RUPTURE DISC WHERE PEOPLE OR PROPERTY WILL NOT BE EXPOSED TO THE SYSTEM DISCHARGE IN CASE OF RUPTURE. VENT TOXIC OR FLAMMABLE FUMES OR LIQUIDS TO A SAFE LOCATION TO PREVENT PERSONAL INJURY OR PROPERTY DAMAGE.

IT IS THE USER'S SOLE RESPONSIBILITY TO SPECIFY THE BURST PRESSURE RATING OF A RUPTURE DISC AT A COINCIDENT TEMPERATURE AT WHICH THE RUPTURE DISC IS TO BE USED. A RUPTURE DISC IS A TEMPERATURE SENSITIVE DEVICE. THE BURST PRESSURE OF THE RUPTURE DISC IS DIRECTLY AFFECTED BY ITS EXPOSURE TO THE COINCIDENT TEMPERATURE. GENERALLY, AS THE TEMPERATURE AT THE RUPTURE DISC INCREASES, THE BURST PRESSURE DECREASES; INVERSELY, AS THE TEMPERATURE AT THE RUPTURE DISC DECREASES, THE BURST PRESSURE MAY INCREASE. FAILURE TO PROPERLY UTILIZE A RUPTURE DISC AT THE SPECIFIED COINCIDENT TEMPERATURE COULD CAUSE PREMATURE FAILURE OR OVERPRESSURIZATION OF A SYSTEM.

THE INSTANTANEOUS RELEASE OF PRESSURE FROM THE RUPTURE DISC CAN CREATE VIOLENT NOISES DUE TO THE DISCHARGE AT SONIC VELOCITY. IT IS THE USER'S SOLE RESPONSIBILITY TO PROTECT AGAINST HEARING DAMAGE TO ANY BYSTANDERS.

RUPTURE DISCS AND TAGS ARE MADE OF METAL FOILS OF VARYING THICKNESS. THE METAL EDGES MAY BE SHARP. PERSONNEL INSTALLING OR EXAMINING THE RUPTURE DISCS SHOULD PROTECT AGAINST CUTS OR INJURY WHEN HANDLING THE RUPTURE DISC. DO NOT LIFT A RUPTURE DISC BY ITS ATTACHED TAG.

PARTICLES MAY BE DISCHARGED WHEN THE RUPTURE DISC RUPTURES. THESE PARTICLES MAY BE PART OF THE RUPTURE DISC ITSELF, OR OTHER ENVIRONMENTAL MATTER IN THE SYSTEM. IT IS THE USER'S SOLE RESPONSIBILITY TO ASSURE THAT THESE PARTICLES ARE DIRECTED TO A SAFE AREA TO PREVENT PERSONAL INJURY OR PROPERTY DAMAGE.

THERE IS NO GUARANTEE OF RUPTURE DISC LIFE. SUCH LIFE SPAN IS AFFECTED BY CORROSION, CREEP AND FATIGUE, AND PHYSICAL DAMAGE. THESE CONDITIONS WILL DERATE THE RUPTURE DISC TO A LOWER SET PRESSURE. THE CUSTOMER AND/OR USER SHOULD BE PREPARED TO HANDLE PREMATURE FAILURE OF THE RUPTURE DISC. THE MEDIA OR OTHER ENVIRONMENTAL CONDITIONS SHOULD NOT ALLOW ANY BUILDUP OR SOLIDIFICATION OF MEDIA TO OCCUR ON A RUPTURE DISC. THIS MAY INCREASE THE PRESSURE SETTING OF THE RUPTURE DISC.

CUSTOMER AND/OR ITS INSTALLER SHALL BE SOLELY RESPONSIBLE FOR THE PROPER INSTALLATION OF SELLER'S HOLDERS AND RUPTURE DISCS INTO A SYSTEM. CUSTOMER AND/OR ITS INSTALLER SHALL BE SOLELY RESPONSIBLE FOR IMPROPER INSTALLATION AND PHYSICAL DAMAGE RESULTING THEREFROM, INCLUDING BUT NOT LIMITED TO, DAMAGE RESULTING FROM LEAKAGE, IMPROPER TORQUING OR SEATING OF A RUPTURE DISC OR FAILURE TO FOLLOW INSTALLATION INSTRUCTIONS WHERE PROVIDED.

RUPTURE DISCS ARE PRECISION SAFETY DEVICES AND MUST BE INSTALLED PROPERLY. RUPTURE DISCS MUST BE INSTALLED BY TRAINED, KNOWLEDGEABLE INSTALLERS AND ONLY WITHIN ENVIRONMENTS SUITABLE AND APPROPRIATE FOR A RUPTURE DISC. CARE MUST BE USED IN A FACILITY'S DESIGN TO PROTECT BOTH THE RUPTURE DISC FROM INADVERTENT DAMAGE WHICH COULD CAUSE ITS PREMATURE RELEASE AND TO PROTECT INDIVIDUALS EXPOSED TO HAZARDS CREATED BY SUCH SUDDEN RELEASE.

PROPER INSTALLATION OF A RUPTURE DISC IS CRITICAL TO PERFORMANCE AND TO SAFETY. FAILURE TO PROVIDE PROPER SEATING OF A RUPTURE DISC MAY AFFECT RUPTURE DISC PERFORMANCE, BURST PRESSURE ACCURACY AND MAY RESULT IN ITS PREMATURE FAILURE.

I. Safety Precautions Before Installation

1. The knifeblades are very sharp. Care must be taken during handling to prevent serious bodily injury. The knifeblades must be free of corrosion, nicks, or bent points to ensure proper performance. If any of these conditions exist, the rating of the rupture disc will increase beyond the original rupture pressure rating.
2. The KBA rupture disc is a precision instrument and must be handled with extreme care. Rupture discs should be installed only by qualified personnel familiar with rupture discs and proper piping practices.
3. Do not install rupture disc if there is any damage in the dome area. A damaged rupture disc is any rupture disc with visible nicks or dents in the dome.
4. Continental Disc Corporation does not recommend reinstalling a rupture disc that has been removed from the holder as reinstallation may adversely affect the joint sealing capabilities and/or performance of the rupture disc.

II. Preparation of Holders for Installation

New Installation

Clean all foreign material from the rupture disc sealing areas.

Replacement Installation

1. If the B.D.I.[®] (Burst Disc Indicator) Alarm System is used, disconnect the alarm strip from the monitor by unplugging the B.D.I. connector from the lead wire connector.
2. Remove the holder from the system and place on a flat surface.
3. Disassemble the holder by loosening the pre-assembly screws or by removing the pre-assembly cap screws on the holder outlet. Lift the holder outlet up and set aside; then remove the burst rupture disc.
4. Clean the rupture disc sealing area of both the holder inlet and outlet. These surfaces must be completely clean and free of all rust, corrosion, and foreign material to ensure a proper seal. Use of solvents, steel wool, or fine emery cloth is permissible. Do not re-machine. Do not use scraper or abrasives.
5. Inspect the rupture disc sealing area for nicks, scratches, or pitting. If any of these conditions are present, consult the factory for repair.
6. **EXAMINE THE KNIFEBLADE CONDITION. BLADE EDGES AND POINTS MUST BE SHARP TO ENSURE PROPER RUPTURE DISC FUNCTION. DO NOT INSTALL RUPTURE DISC IF BLADE EDGES OR POINTS ARE DAMAGED OR CORRODED. IF BLADES ARE IN NEED OF SHARPENING OR REPLACEMENT, THIS MUST BE PERFORMED AT THE FACTORY.**
7. Knifeblades are designed for specific rupture disc ratings. **DO NOT INSTALL RUPTURE DISC IF CURRENT PRESSURE CONDITIONS DIFFER FROM THAT OF THE INITIAL INSTALLATION OR IF RUPTURE DISC RATING EXCEEDS MAXIMUM RUPTURE DISC RATING STAMPED ON HOLDER NAMEPLATE.** Consult the factory should these conditions occur.
8. Remove any adhered gasket material from previous installation.

III. Assembly of the Rupture Disc and Holder (See Figure A)

Component parts of the KBA Assembly are illustrated in the proper installation sequence.

1. If the B.D.I. Alarm System is to be used, see the Universal B.D.I. Assembly installation instruction for additional details.
2. Carefully remove and discard any shipping protectors furnished with rupture discs or holder. **DO NOT INSTALL A SHIPPING PROTECTOR IN A HOLDER ASSEMBLY.**
3. Place the holder inlet on a flat surface.
4. Place the KBA rupture disc, dome side down, on the holder inlet opening as illustrated.

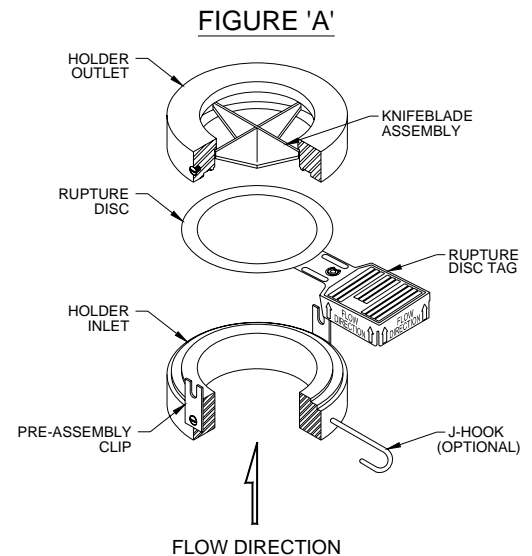

- Align and lower the holder outlet carefully onto the holder inlet.
- Fasten the assembly together by tightening the pre-assembly screws or by replacing and tightening the pre-assembly cap screws.

IV. Installation of the KBA Assembly Into the System (See Figure B)

- Before placing the assembly into the system, ensure that the companion flange gasket surfaces are clean and free of all rust, corrosion, and foreign material.
- A J-Hook (Optional) may be provided in the holder inlet to ensure correct installation of the assembly relative to flow direction. If the J-Hook is used, the corresponding inlet companion flange must be drilled to accommodate the J-Hook prior to installation of the assembly. Refer to the J-Hook Installation Guide for locating and drilling specifications.
- Install the KBA assembly and customer furnished gaskets **WITH ALL FLOW ARROWS POINTING IN THE PROPER FLOW DIRECTION** and the J-Hook (if furnished) inserted into the drilled companion flange.
- If a Teflon[®] outlet protective cover is ordered, install it between the KBA rupture disc assembly and the gasket of the outlet companion flange.
- Install lightly oiled, free running studs and nuts to finger tightness. Using a cross torquing pattern (see Figure C), torque each nut with a calibrated torque wrench at 20% increments of the recommended torque value in Table 1. Repeat 20% increments and cross torquing pattern until final torque value is achieved. Recheck all nuts in rotational sequence at final torque value. These values are based on using gasket materials having a gasket factor of 2.75, gasket seating stress of 3,700 psi, and stud and nut material per ASME SA193-B7 and SA194-2H respectively, with a stress of up to 25,000 psi. The use of studs and nuts with lower strength may prove unsatisfactory.

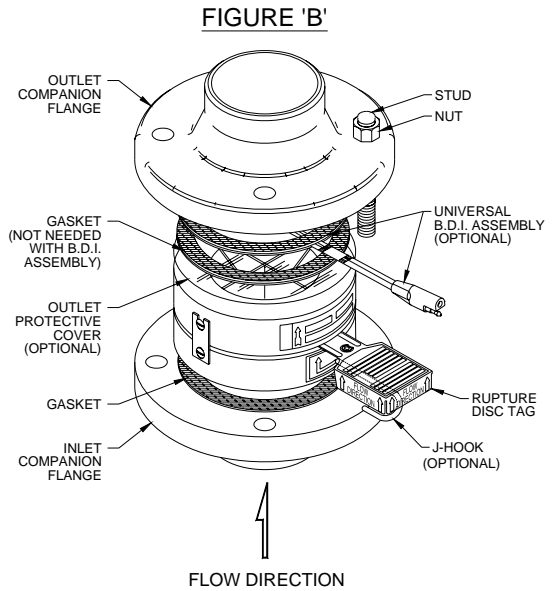
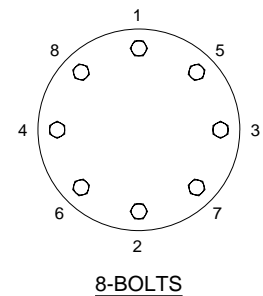

FIGURE 'C'
EXAMPLE OF BOLT TORQUE SEQUENCE



V. Preventative Maintenance

- Risk assessment and an annual rupture disc replacement are recommended. Rupture disc service life is determined by system operating conditions. The effects of severe pressure/vacuum cycles, corrosion, temperature variations, or other adverse conditions must be evaluated by the user through actual service experience to determine optimal service life.
- IF THE RUPTURE DISC IS NOT REPLACED PERIODICALLY WHEN EXPOSED TO THESE CONDITIONS, PREMATURE FAILURE OF THE RUPTURE DISC MAY OCCUR, THEREBY DISCHARGING THE PROCESS MEDIA.**
- INSPECT KNIFEBLADE CONDITION AT EACH RUPTURE DISC CHANGEOUT.** See Section II, Items 6 and 7. Consult the factory if knifeblade replacement is required.
- To avoid extended downtime, maintain three spare rupture discs in stock at all times for each holder in use. The number of spares required ultimately will be determined by service conditions.

*Teflon is a registered trademark of E.I. du Pont deNemours and company used under license.

VI. Customer Service

If you wish to discuss your application, installation, or maintenance, please contact the Customer Service Department at one of the addresses shown on the last page of these instructions.

Burst Disc Indicator (B.D.I.) Alarm System incorporates U.S. patent no. Re. 34,308 and 4,408,194; Australia patent no. 539415; Germany patent no. 3174227.0; Belgium, France and United Kingdom patent no. EP 0 033 867; Canada patent no. 1199990; Japan patent no. 2032464.

B.D.I. ALARM SYSTEM OPERATING LIMITS

TEMPERATURE: -40° F to + 400° F
(-40° C to + 204° C)

MAX CURRENT: 50 Milli Amps
MAX VOLTAGE: 24 VDC RMS

BURST DISC INDICATOR (B.D.I.®): Sizes 25mm through 900mm (1 inch through 36 inches)

Marked:  II 2 G D EEx ia IIC
(Tamb = -40° C to +204° C)

EC Type Examination Certificate: ITSO3ATEX 21357U

FULFILL THE REQUIREMENTS OF DIRECTIVE 94/9 EC (ATEX) FOR: COMPONENTS of equipment and protective systems intended for use in potentially explosive atmospheres.

APPLIED HARMONIZED STANDARD: EN 50 014: 1997 + Amds 1 & 2 General Requirements
EN 50 020: 2002, Intrinsic Safety

ADDITIONAL INFORMATION: Conformity assessment performed by Notified Body no. 0359,
ITS Testing and Certification Limited, Leatherhead, Surry, UK.

Recommended Torque Values for KBA
Rupture Discs Sizes 1" through 32"
TABLE 1

SIZE		COMPANION FLANGE RATING			RECOMMENDED TORQUE VALUE		SIZE		COMPANION FLANGE RATING			RECOMMENDED TORQUE VALUE	
					Ft•Lbs	N•m						Ft•Lbs	N•m
1	25	150	----	----	35	47	8	200	----	16	10	77	104
1	25	----	10/16	----	33	45	8	200	----	----	16/20	85	115
1	25	----	----	10/20	44	60	8	200	300	----	----	185	251
1	25	300/600	----	----	65	88	8	200	----	25	30	200	271
1	25	----	25/40	----	49	66	8	200	----	40	----	225	305
1	25	----	----	30/40	66	89							
							10	250	150	----	----	185	251
1-1/2	40	150	----	----	35	47	10	250	----	10	----	166	225
1-1/2	40	----	10/16	10/20	44	60	10	250	----	----	10	183	248
1-1/2	40	300/600	----	----	110	149	10	250	----	16	16/20	200	271
1-1/2	40	----	25/40	----	92	125	10	250	300	----	----	260	352
1-1/2	40	----	----	30/40	115	156	10	250	----	25	----	369	500
							10	250	----	40	30	409	555
2	50	150	----	----	65	88							
2	50	----	10/16	10	66	89	12	300	150	----	----	185	251
2	50	----	----	16/20	33	45	12	300	----	10	----	166	225
2	50	300/600	----	----	65	88	12	300	----	----	10	137	186
2	50	----	25/40	----	131	178	12	300	----	16	----	200	271
2	50	----	----	30/40	66	89	12	300	----	----	16/20	150	203
							12	300	300	----	----	375	508
2-1/2	65	150	---	---	65	88							
2-1/2	65	---	10/16	10	33	45	14	350	150	----	----	260	352
2-1/2	65	---	---	16/20	66	89	14	350	----	10	----	166	225
2-1/2	65	300/600	---	---	110	149	14	350	----	----	10	137	186
2-1/2	65	---	25/40	---	131	178	14	350	----	16	----	200	271
2-1/2	65	---	---	30/40	66	89	14	350	----	----	16/20	150	203
							14	350	300	----	----	375	508
3	80	150	----	----	65	88							
3	80	----	10/16	10	33	45	16	400	150	----	----	260	352
3	80	----	----	16/20	41	56	16	400	----	10	10	246	334
3	80	300/600	----	----	110	149	16	400	----	16	----	276	374
3	80	----	25/40	----	131	178	16	400	----	----	16/20	307	416
3	80	----	----	30/40	66	89	16	400	300	----	----	485	658
4	100	150	----	----	65	88	18	450	150	----	----	375	508
4	100	----	10/16	10	66	89	18	450	----	----	10	252	342
4	100	----	----	16/20	82	111	18	450	----	----	16/20	315	427
4	100	300	----	----	110	149							
4	100	----	25/40	----	115	156	20	500	150	----	----	375	508
4	100	----	----	30	127	172	20	500	----	10	10	262	355
4	100	600	----	----	185	251	20	500	----	16	16/20	397	538
4	100	----	----	40	183	248							
							24	600	150	----	----	485	658
6	150	150	----	----	110	149	24	600	----	10	----	367	498
6	150	----	10/16	10	115	156	24	600	----	----	10	382	518
6	150	----	----	16/20	85	115	24	600	----	16	----	504	683
6	150	300	----	----	110	149	24	600	----	----	16/20	458	621
6	150	----	25/40	----	208	282							
6	150	----	----	30	139	188	28	700	150	----	----	485	658
6	150	600	----	----	260	352							
6	150	----	----	40	246	334	30	750	150	----	----	485	658
8	200	150	----	----	110	149	32	800	150	----	----	875	1186
8	200	----	10	----	115	156							



**Continental Disc[®]
Corporation**

Performance Under Pressure[®]



Certified Quality System
First Certified In 1992



ASME Code Symbol Stamp
If stamped, this product is built in accordance with the requirements of the ASME Boiler and Pressure Vessel Code, Section VIII, Division 1.

China Manufacture License

Products are in full compliance with the provisions of the People's Republic of China Import Regulations for Boiler and Pressure Vessel safety devices.



3A Sanitary Standards Stamp
If stamped, this product is in full compliance with the 3A standards, Serial #60-00, of the International Association of Milk, Food, and Environmental Sanitarians, Inc.



**European Union CE Mark
Type Approval Stamp**
If stamped, this product is certified to conform to the essential requirements of the Pressure Equipment Directive.

Continental Disc Corporation has representatives located throughout the world.
Contact the C.D.C. office nearest you for the authorized representative in your area.

CORPORATE HEADQUARTERS

Continental Disc Corporation

3160 W. Heartland Drive
Liberty, Missouri 64068-3385 USA
Phone: (816) 792-1500
FAX: (816) 792-2277 / 5447
E-mail: pressure@contdisc.com
Website: www.contdisc.com

THE NETHERLANDS

Continental Disc Corporation
Energieweg 20
2382 NJ Zoeterwoude-Rijndijk
The Netherlands
Phone: +(31) 71-5412221
FAX: +(31) 71-5414361
E-mail: cdcnl@contdisc.com

UNITED KINGDOM

Continental Disc UK Ltd.
Unit C, The Business Centre
Faringdon Avenue, Hardd Hill
Romford, Essex RM3 8EN
United Kingdom
Phone: +(44) 1708-386444
FAX: +(44) 1708-386486
E-mail: cduk@contdisc.com

CHINA

Continental Disc Corporation
Room 910, Tower B, COFCO Plaza
No. 8 JianGuoMenNei Avenue
Beijing (100005)
P.R. China
Mobile: +(86) 137 0103 8871
E-mail: cdcchina@contdisc.com

DUBAI

Continental Disc Corporation
P. O. Box 2234
Dubai, U.A.E.
Phone: +(971) 43214490
Fax: +(971) 43438840
Mobile: +(971) 508129525
E-mail: kannan@contdisc.com