



**Continental Disc<sup>®</sup>  
Corporation**

## **Preparation and Installation of the SANITRX<sup>®</sup> / SANITRX LP<sup>®</sup> (IS) Rupture Disc for Use With Industry Standard Ferrules**

### **WARNING**

USER SHOULD READ AND THOROUGHLY UNDERSTAND THESE INSTRUCTIONS BEFORE INSTALLING RUPTURE DISC. THESE INSTRUCTIONS DO NOT PURPORT TO ADDRESS ALL OF THE SAFETY FACTORS ASSOCIATED WITH THE RUPTURE DISC'S USE IN SERVICE. IT IS THE RESPONSIBILITY OF THE USER TO ESTABLISH APPROPRIATE SAFETY, HEALTH, AND TRAINING MEASURES FOR THEIR PERSONNEL INSTALLING, SERVICING, OR WORKING IN AN AREA WHERE RUPTURE DISC ASSEMBLIES ARE IN USE. SERVICE AND/OR MAINTENANCE ON OR AROUND THE RUPTURE DISC DEVICE MUST NOT BE PERFORMED WHILE THE DEVICE IS SUBJECTED TO OPERATING PRESSURES AND/OR TEMPERATURES.

IT IS THE USER'S SOLE RESPONSIBILITY FOR DESIGN AND PLACEMENT OF RUPTURE DISCS WITHIN THEIR FACILITY AND UPON THE EQUIPMENT UPON WHICH THE RUPTURE DISC OF USER'S SELECTION IS TO BE LOCATED. IT IS USER'S SOLE RESPONSIBILITY FOR THE DESIGN OF ADEQUATE VENTING AND INSTALLATION OF ADEQUATE VENT PIPING OR DIRECTIONAL FLOW AFTER RUPTURE OCCURS WITH THE RUPTURE DISC AS INTENDED. WHEN SIZE IS SPECIFIED, CONTINENTAL DISC CORPORATION ASSUMES THAT ADEQUATE PROVISIONS HAVE BEEN MADE BY PURCHASER FOR PROPER VENTING OF A SYSTEM TO RELIEVE THE SPECIFIC PRESSURE. LOCATE RUPTURE DISC WHERE PEOPLE OR PROPERTY WILL NOT BE EXPOSED TO THE SYSTEM DISCHARGE IN CASE OF RUPTURE. VENT TOXIC OR FLAMMABLE FUMES OR LIQUIDS TO A SAFE LOCATION TO PREVENT PERSONAL INJURY OR PROPERTY DAMAGE.

IT IS THE USER'S SOLE RESPONSIBILITY TO SPECIFY THE BURST PRESSURE RATING OF A RUPTURE DISC AT A COINCIDENT TEMPERATURE AT WHICH THE RUPTURE DISC IS TO BE USED. A RUPTURE DISC IS A TEMPERATURE SENSITIVE DEVICE. THE BURST PRESSURE OF THE RUPTURE DISC IS DIRECTLY AFFECTED BY ITS EXPOSURE TO THE COINCIDENT TEMPERATURE. GENERALLY, AS THE TEMPERATURE AT THE RUPTURE DISC INCREASES, THE BURST PRESSURE DECREASES; INVERSELY, AS THE TEMPERATURE AT THE RUPTURE DISC DECREASES, THE BURST PRESSURE MAY INCREASE. FAILURE TO PROPERLY UTILIZE A RUPTURE DISC AT THE SPECIFIED COINCIDENT TEMPERATURE COULD CAUSE PREMATURE FAILURE OR OVERPRESSURIZATION OF A SYSTEM.

THE INSTANTANEOUS RELEASE OF PRESSURE FROM THE RUPTURE DISC CAN CREATE VIOLENT NOISES DUE TO THE DISCHARGE AT SONIC VELOCITY. IT IS THE USER'S SOLE RESPONSIBILITY TO PROTECT AGAINST HEARING DAMAGE TO ANY BYSTANDERS.

RUPTURE DISCS AND TAGS ARE MADE OF METAL FOILS OF VARYING THICKNESS. THE METAL EDGES MAY BE SHARP. PERSONNEL INSTALLING OR EXAMINING THE RUPTURE DISCS SHOULD PROTECT AGAINST CUTS OR INJURY WHEN HANDLING THE RUPTURE DISC. DO NOT LIFT A RUPTURE DISC BY ITS ATTACHED TAG.

PARTICLES MAY BE DISCHARGED WHEN THE RUPTURE DISC RUPTURES. THESE PARTICLES MAY BE PART OF THE RUPTURE DISC ITSELF, OR OTHER ENVIRONMENTAL MATTER IN THE SYSTEM. IT IS THE USER'S SOLE RESPONSIBILITY TO ASSURE THAT THESE PARTICLES ARE DIRECTED TO A SAFE AREA TO PREVENT PERSONAL INJURY OR PROPERTY DAMAGE.

THERE IS NO GUARANTEE OF RUPTURE DISC LIFE. SUCH LIFE SPAN IS AFFECTED BY CORROSION, CREEP AND FATIGUE, AND PHYSICAL DAMAGE. THESE CONDITIONS WILL DERATE THE RUPTURE DISC TO A LOWER SET PRESSURE. THE CUSTOMER AND/OR USER SHOULD BE PREPARED TO HANDLE PREMATURE FAILURE OF THE RUPTURE DISC. THE MEDIA OR OTHER ENVIRONMENTAL CONDITIONS SHOULD NOT ALLOW ANY BUILDUP OR SOLIDIFICATION OF MEDIA TO OCCUR ON A RUPTURE DISC. THIS MAY INCREASE THE PRESSURE SETTING OF THE RUPTURE DISC.

CUSTOMER AND/OR ITS INSTALLER SHALL BE SOLELY RESPONSIBLE FOR THE PROPER INSTALLATION OF SELLER'S HOLDERS AND RUPTURE DISCS INTO A SYSTEM. CUSTOMER AND/OR ITS INSTALLER SHALL BE SOLELY RESPONSIBLE FOR IMPROPER INSTALLATION AND PHYSICAL DAMAGE RESULTING THEREFROM, INCLUDING BUT NOT LIMITED TO, DAMAGE RESULTING FROM LEAKAGE, IMPROPER TORQUING OR SEATING OF A RUPTURE DISC OR FAILURE TO FOLLOW INSTALLATION INSTRUCTIONS WHERE PROVIDED.

RUPTURE DISCS ARE PRECISION SAFETY DEVICES AND MUST BE INSTALLED PROPERLY. RUPTURE DISCS MUST BE INSTALLED BY TRAINED, KNOWLEDGEABLE INSTALLERS AND ONLY WITHIN ENVIRONMENTS SUITABLE AND APPROPRIATE FOR A RUPTURE DISC. CARE MUST BE USED IN A FACILITY'S DESIGN TO PROTECT BOTH THE RUPTURE DISC FROM INADVERTENT DAMAGE WHICH COULD CAUSE ITS PREMATURE RELEASE AND TO PROTECT INDIVIDUALS EXPOSED TO HAZARDS CREATED BY SUCH SUDDEN RELEASE.

PROPER INSTALLATION OF A RUPTURE DISC IS CRITICAL TO PERFORMANCE AND TO SAFETY. FAILURE TO PROVIDE PROPER SEATING OF A RUPTURE DISC MAY AFFECT RUPTURE DISC PERFORMANCE, BURST PRESSURE ACCURACY AND MAY RESULT IN ITS PREMATURE FAILURE.

## I. Safety Precautions Before Installation

1. The SANITRX® / SANITRX LP® (IS) rupture disc is a precision instrument and must be handled with extreme care. Rupture discs should be installed only by qualified personnel familiar with rupture discs and proper piping practices.
2. The SANITRX / SANITRX LP (IS) rupture disc shall be installed between existing tube O.D. industry standard sanitary ferrules and be secured by a bolted or wing nut type clamp or equivalent.
3. The SANITRX / SANITRX LP (IS) rupture disc includes factory installed nonsymmetrical indentations positioned on the rupture disc dome (see Figure A). Do not install rupture disc if there is any damage evident. A damaged rupture disc is any rupture disc with visible nicks or dents in the dome.

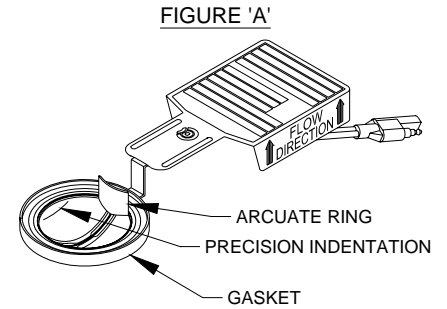

## II. Preparation of Sanitary Fittings for Rupture Disc Installation

### New Installation

Clean all foreign material from the rupture disc sealing area of both the sanitary fitting inlet and outlet.

### Replacement Installation

1. If the Burst Disc Indicator (B.D.I.®) Alarm System is used, disconnect the alarm strip from the monitor by unplugging the B.D.I. connector from the lead wire connector.
2. Clean the rupture disc sealing areas of both the sanitary fitting inlet and outlet. These surfaces must be completely clean and free of all rust, corrosion, and foreign material to ensure a proper seal. Do not use scraper or abrasives.
3. Inspect the rupture disc sealing areas for nicks, scratches, or pitting. If any of these conditions are present, do not install the rupture disc.
4. Remove any adhered gasket material from previous installation.

## III. Installation of the SANITRX / SANITRX LP (IS) Rupture Disc into the System (See Figure B)

1. Before placing the SANITRX / SANITRX LP (IS) rupture disc into the system, ensure that the gasket surfaces are clean and free of all corrosion and foreign material.
2. If the Sanitary B.D.I. Alarm System is used, visually inspect the adhesion of the strip to the Teflon® seal and the electrical circuit. If the strip has become detached or the circuit has been broken, **DO NOT INSTALL THE RUPTURE DISC.**

**CAUTION: WHEN INSTALLING THE RUPTURE DISC, ASSURE THAT THE FLOW DIRECTIONAL ARROWS ON THE RUPTURE DISC THREE-DIMENSIONAL TAG POINT IN THE VENT DIRECTION OF THE RELIEF SYSTEM.**

3. Install the SANITRX / SANITRX LP (IS) rupture disc into the sanitary fitting inlet ferrule. Secure the sanitary fitting inlet ferrule, SANITRX / SANITRX LP (IS) rupture disc, and sanitary fitting outlet ferrule with the appropriate size CDC MBC Sanitary Closure, wing nut clamp, or Tri-Clamp™ 13 MHHM or equivalent. For the wing nut clamp, the hinge portion of the clamp must be positioned adjacent to the rupture disc tag. For the MBC Sanitary Closure, either side of the bolted portion of the clamp must be positioned adjacent to the rupture disc tag.

\*Teflon is a registered trademark of E.I. du Pont de Nemours and Company used under license.

\*\*Tri-Clamp is a registered trademark of Tri-Clover, Inc.

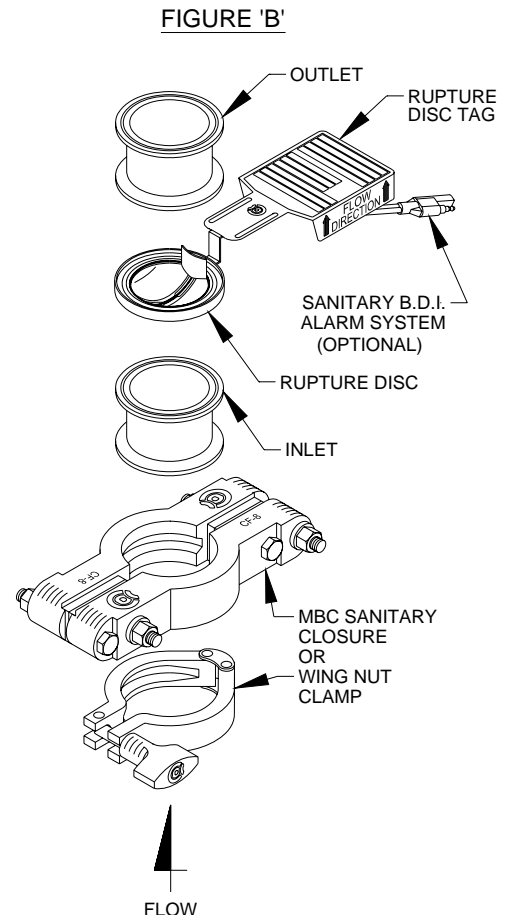

4. If the B.D.I. Alarm System is used, installation of the strain relief mounting tab is necessary.
  - a. Before tightening the clamp, install the strain relief mounting tab.
  - b. Slide the mounting tab over the clamp stud as shown in Figure C and then torque as necessary.
  - c. Insert the lead wire into the standoff clip.
5. If the wing nut clamp is used, torque the wing nut with a calibrated torque wrench to a recommended torque value of 30 In•Lbs / (3.4 N•m) using a 1-5/16" HEX SOCKET.
6. If the MBC Sanitary Closure is used, install free running bolts and nuts to finger tightness. Torque nuts number 1 and 2 with a calibrated torque wrench at 50% increments to a final torque of 20 Ft•Lbs / (27 N•m). Maintain an equal and parallel gap between the clamp halves throughout the torque sequence. Based on gasket material type and rupture disc material thickness, the torque compression may close the gap between the clamp halves. Torque nuts number 3 and 4 using the same criteria as nuts 1 and 2.
7. If the sanitary B.D.I. Alarm System is used, plug the B.D.I. connector into the lead wire connector using a slight twisting action.

**Figure 'C'**

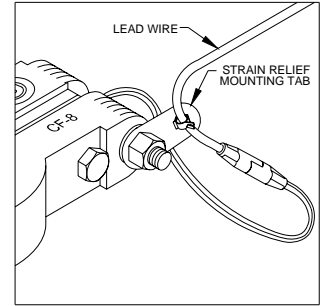

#### IV. Preventative Maintenance

1. Replace rupture disc every year under normal conditions. A more frequent changeout may be necessary due to corrosion, fatigue, temperature, or adverse conditions. These factors must be evaluated by the user through actual service experience.
2. **IF THE RUPTURE DISC IS NOT REPLACED PERIODICALLY WHEN EXPOSED TO THESE CONDITIONS, PREMATURE FAILURE OF THE RUPTURE DISC MAY OCCUR, THEREBY DISCHARGING THE PROCESS MEDIA.**
3. To avoid extended downtime, maintain three spare rupture discs in stock at all times for each holder in use. The number of spares required ultimately will be determined by service conditions.

**FIGURE 'D'**  
EXAMPLE OF  
BOLT TORQUE SEQUENCE

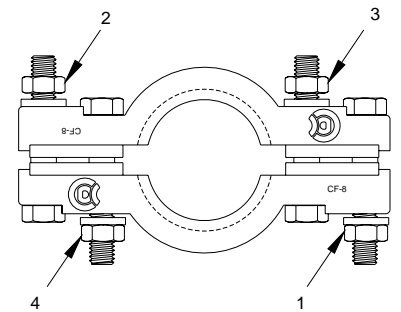

#### V. Customer Service

If you wish to discuss your application, installation, or maintenance, please contact the Customer Service Department at one of the addresses shown on the last page of these instructions.

SANITRX / SANITRX LP incorporate U.S. patent nos. 4,512,171, 4,072,160, 4,597,505, 4,759,460, and 4,669,626; Chile patent no. 35,096; Spain patent no. 289,581; India patent no. 160,204; France, Netherlands, and United Kingdom patent no. EP 0 137 903; Germany patent no. P 3473633.6; Canada patent no. 1,244,315; Australia patent no. 579,833; Venezuela patent no. 46.640; Ireland patent no. 55,493; Mexico patent no. 161,587.

SANITRX LP incorporates U.S. patent no. 6,241,113.

Burst Disc Indicator (B.D.I.) Alarm System incorporates U.S. patent nos. Re. 34,308 and 4,408,194; Australia patent no. 539415; Germany patent no. 3174227.0; Belgium, France and United Kingdom patent no. EP 0 033 867; Canada patent no. 1199990; Japan patent no. 2032464.

##### B.D.I. ALARM SYSTEM OPERATING LIMITS

TEMPERATURE:      -40° F to + 400° F                      MAX CURRENT: 50 Milli Amps  
                               (-40° C to + 204° C)                      MAX VOLTAGE: 24 VDC RMS

BURST DISC INDICATOR (B.D.I.®): Sizes 25mm through 900mm (1 inch through 36 inches)

Marked:  II 2 G D EEx ia IIC  
 (Tamb = -40° C to +204° C)

EC Type Examination Certificate:    ITSO3ATEX 21357U

FULFILLS THE REQUIREMENTS OF DIRECTIVE 94/9/EC (ATEX) FOR: COMPONENTS of equipment and protective systems intended for use in potentially explosive atmospheres.

APPLIED HARMONIZED STANDARD:    EN 50 014: 1997 + Amds 1 & 2 General Requirements  
     EN 50 020: 2002, Intrinsic Safety

ADDITIONAL INFORMATION:    Conformity assessment performed by Notified Body no. 0359,  
     ITS Testing and Certification Limited, Leatherhead, Surrey, UK.

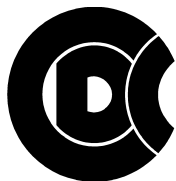

# Continental Disc<sup>®</sup> Corporation

**Performance Under Pressure<sup>®</sup>**

A Siegel-Robert Company



**Certified Quality System**  
First Certified In 1992



**ASME Code Symbol Stamp**  
If stamped, this product is built in accordance with the requirements of the ASME Boiler and Pressure Vessel Code, Section VIII, Division 1.



**China Manufacture License Type Approval Stamp**  
If stamped, this product is in full compliance with the provisions of the Peoples Republic of China Import Regulations for Boiler and Pressure Vessel safety devices.



**3A Sanitary Standards Stamp**  
If stamped, this product is in full compliance with the 3A standards, Serial #60-00, of the International Association of Milk, Food, and Environmental Sanitarians, Inc.



**European Union CE Mark Type Approval Stamp**  
If stamped, this product is certified to conform to the essential requirements of the Pressure Equipment Directive.

Continental Disc Corporation has representatives located throughout the world.  
Contact the C.D.C. office nearest you for the authorized representative in your area.

## CORPORATE HEADQUARTERS

### Continental Disc Corporation

3160 W. Heartland Drive  
Liberty, Missouri 64068-3385 USA  
Phone: (816) 792-1500  
FAX: (816) 792-2277 / 5447  
E-mail: [pressure@contdisc.com](mailto:pressure@contdisc.com)

#### THE NETHERLANDS

Continental Disc Corporation  
Energieweg 20  
2382 NJ Zoeterwoude-Rijndijk  
The Netherlands  
Phone: +(31) 71-5412221  
Fax: +(31) 71-5414361  
E-mail: [cdcnl@contdisc.com](mailto:cdcnl@contdisc.com)

#### GERMANY

Continental Disc Deutschland GmbH  
Virmondstrasse 151  
47877 Willich  
Germany  
Phone: +(49) 2156-490802  
Fax: +(49) 2156-492547  
E-mail: [cdd@contdisc.com](mailto:cdd@contdisc.com)

#### UNITED KINGDOM

Continental Disc UK Ltd.  
Unit C, The Business Centre  
Faringdon Avenue, Harold Hill,  
Romford  
Essex RM3 8EN  
United Kingdom  
Phone: +(44) 1708-386444  
Fax: +(44) 1708-386486  
E-mail: [cduk@contdisc.com](mailto:cduk@contdisc.com)

#### CHINA

Continental Disc Corporation  
2026 The Executive Center  
20/F The Center  
989 Changle Rd.  
Shanghai, 200031  
P.R. China  
Phone: +(86) 21-5117-5848  
Fax: +(86) 21-5117-5849  
Mobile: +(86) 137-8897-2291  
E-mail: [jyang@contdisc.com](mailto:jyang@contdisc.com)

#### DUBAI

Continental Disc Corporation  
P. O. Box 2234  
Dubai, U.A.E.  
Phone: +(971) 43214490  
Fax: +(971) 43438840  
Mobile: +(971) 508129525  
E-mail: [kannan@contdisc.com](mailto:kannan@contdisc.com)