



**Continental Disc
Corporation**

Preparation and Installation of the SANITRX® HPX Rupture Disc

WARNING

USER SHOULD READ AND THOROUGHLY UNDERSTAND THESE INSTRUCTIONS BEFORE INSTALLING RUPTURE DISC. THESE INSTRUCTIONS DO NOT PURPORT TO ADDRESS ALL OF THE SAFETY FACTORS ASSOCIATED WITH THE RUPTURE DISC'S USE IN SERVICE. IT IS THE RESPONSIBILITY OF THE USER TO ESTABLISH APPROPRIATE SAFETY, HEALTH, AND TRAINING MEASURES FOR THEIR PERSONNEL INSTALLING, SERVICING, OR WORKING IN AN AREA WHERE RUPTURE DISC ASSEMBLIES ARE IN USE. SERVICE AND/OR MAINTENANCE ON OR AROUND THE RUPTURE DISC DEVICE MUST NOT BE PERFORMED WHILE THE DEVICE IS SUBJECTED TO OPERATING PRESSURES AND/OR TEMPERATURES.

IT IS THE USER'S SOLE RESPONSIBILITY FOR DESIGN AND PLACEMENT OF RUPTURE DISCS WITHIN THEIR FACILITY AND UPON THE EQUIPMENT UPON WHICH THE RUPTURE DISC OF USER'S SELECTION IS TO BE LOCATED. IT IS USER'S SOLE RESPONSIBILITY FOR THE DESIGN OF ADEQUATE VENTING AND INSTALLATION OF ADEQUATE VENT PIPING OR DIRECTIONAL FLOW AFTER RUPTURE OCCURS WITH THE RUPTURE DISC AS INTENDED. WHEN SIZE IS SPECIFIED, CONTINENTAL DISC CORPORATION ASSUMES THAT ADEQUATE PROVISIONS HAVE BEEN MADE BY PURCHASER FOR PROPER VENTING OF A SYSTEM TO RELIEVE THE SPECIFIC PRESSURE. LOCATE RUPTURE DISC WHERE PEOPLE OR PROPERTY WILL NOT BE EXPOSED TO THE SYSTEM DISCHARGE IN CASE OF RUPTURE. VENT TOXIC OR FLAMMABLE FUMES OR LIQUIDS TO A SAFE LOCATION TO PREVENT PERSONAL INJURY OR PROPERTY DAMAGE.

IT IS THE USER'S SOLE RESPONSIBILITY TO SPECIFY THE BURST PRESSURE RATING OF A RUPTURE DISC AT A COINCIDENT TEMPERATURE AT WHICH THE RUPTURE DISC IS TO BE USED. A RUPTURE DISC IS A TEMPERATURE SENSITIVE DEVICE. THE BURST PRESSURE OF THE RUPTURE DISC IS DIRECTLY AFFECTED BY ITS EXPOSURE TO THE COINCIDENT TEMPERATURE. GENERALLY, AS THE TEMPERATURE AT THE RUPTURE DISC INCREASES, THE BURST PRESSURE DECREASES; INVERSELY, AS THE TEMPERATURE AT THE RUPTURE DISC DECREASES, THE BURST PRESSURE MAY INCREASE. FAILURE TO PROPERLY UTILIZE A RUPTURE DISC AT THE SPECIFIED COINCIDENT TEMPERATURE COULD CAUSE PREMATURE FAILURE OR OVERPRESSURIZATION OF A SYSTEM.

THE INSTANTANEOUS RELEASE OF PRESSURE FROM THE RUPTURE DISC CAN CREATE VIOLENT NOISES DUE TO THE DISCHARGE AT SONIC VELOCITY. IT IS THE USER'S SOLE RESPONSIBILITY TO PROTECT AGAINST HEARING DAMAGE TO ANY BYSTANDERS.

RUPTURE DISCS AND TAGS ARE MADE OF METAL FOILS OF VARYING THICKNESS. THE METAL EDGES MAY BE SHARP. PERSONNEL INSTALLING OR EXAMINING THE RUPTURE DISCS SHOULD PROTECT AGAINST CUTS OR INJURY WHEN HANDLING THE RUPTURE DISC. DO NOT LIFT A RUPTURE DISC BY ITS ATTACHED TAG.

PARTICLES MAY BE DISCHARGED WHEN THE RUPTURE DISC RUPTURES. THESE PARTICLES MAY BE PART OF THE RUPTURE DISC ITSELF, OR OTHER ENVIRONMENTAL MATTER IN THE SYSTEM. IT IS THE USER'S SOLE RESPONSIBILITY TO ASSURE THAT THESE PARTICLES ARE DIRECTED TO A SAFE AREA TO PREVENT PERSONAL INJURY OR PROPERTY DAMAGE.

THERE IS NO GUARANTEE OF RUPTURE DISC LIFE. SUCH LIFE SPAN IS AFFECTED BY CORROSION, CREEP AND FATIGUE, AND PHYSICAL DAMAGE. THESE CONDITIONS WILL DERATE THE RUPTURE DISC TO A LOWER SET PRESSURE. THE CUSTOMER AND/OR USER SHOULD BE PREPARED TO HANDLE PREMATURE FAILURE OF THE RUPTURE DISC. THE MEDIA OR OTHER ENVIRONMENTAL CONDITIONS SHOULD NOT ALLOW ANY BUILDUP OR SOLIDIFICATION OF MEDIA TO OCCUR ON A RUPTURE DISC. THIS MAY INCREASE THE PRESSURE SETTING OF THE RUPTURE DISC.

CUSTOMER AND/OR ITS INSTALLER SHALL BE SOLELY RESPONSIBLE FOR THE PROPER INSTALLATION OF SELLER'S HOLDERS AND RUPTURE DISCS INTO A SYSTEM. CUSTOMER AND/OR ITS INSTALLER SHALL BE SOLELY RESPONSIBLE FOR IMPROPER INSTALLATION AND PHYSICAL DAMAGE RESULTING THEREFROM, INCLUDING BUT NOT LIMITED TO, DAMAGE RESULTING FROM LEAKAGE, IMPROPER TORQUING OR SEATING OF A RUPTURE DISC OR FAILURE TO FOLLOW INSTALLATION INSTRUCTIONS WHERE PROVIDED.

RUPTURE DISCS ARE PRECISION SAFETY DEVICES AND MUST BE INSTALLED PROPERLY. RUPTURE DISCS MUST BE INSTALLED BY TRAINED, KNOWLEDGEABLE INSTALLERS AND ONLY WITHIN ENVIRONMENTS SUITABLE AND APPROPRIATE FOR A RUPTURE DISC. CARE MUST BE USED IN A FACILITY'S DESIGN TO PROTECT BOTH THE RUPTURE DISC FROM INADVERTENT DAMAGE WHICH COULD CAUSE ITS PREMATURE RELEASE AND TO PROTECT INDIVIDUALS EXPOSED TO HAZARDS CREATED BY SUCH SUDDEN RELEASE.

PROPER INSTALLATION OF A RUPTURE DISC IS CRITICAL TO PERFORMANCE AND TO SAFETY. FAILURE TO PROVIDE PROPER SEATING OF A RUPTURE DISC MAY AFFECT RUPTURE DISC PERFORMANCE, BURST PRESSURE ACCURACY AND MAY RESULT IN ITS PREMATURE FAILURE.

I. Safety Precautions Before Installation

1. The SANITRX HPX rupture disc is a precision instrument and must be handled with extreme care. Rupture discs should be installed only by qualified personnel familiar with rupture discs and proper piping practices.
2. The SANITRX HPX rupture disc shall be installed between existing tube O.D. sanitary ferrules or SANITRX ferrules and be secured by a bolted or wing nut type clamp or equivalent.
3. The SANITRX HPX rupture disc may include a factory installed indentation positioned near the apex of the rupture disc dome (see Figure A). Do not install rupture disc if there is any damage evident. A damaged rupture disc is any rupture disc with visible nicks or dents in the dome.
4. See rupture disc tag to verify set pressure, operating temperature, and all other operating parameters.

FIGURE 'A'

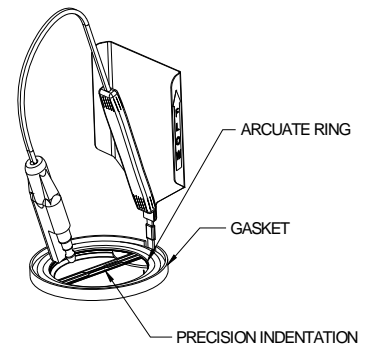

II. Sanitary Fitting

A. Preparation of Sanitary Fittings for Rupture Disc Installation

New Installation

Clean all foreign material from the rupture disc sealing area of both the sanitary fitting inlet and outlet.

Replacement Installation

CAUTION: WHEN INSTALLING A NEW RUPTURE DISC, ASSURE THAT THE FLOW DIRECTIONAL ARROWS ON THE RUPTURE DISC THREE DIMENSIONAL TAG POINT IN THE VENT DIRECTION OF THE RELIEF SYSTEM.

- a. If the Burst Disc Indicator (B.D.I.®) Alarm System is used, disconnect the alarm strip from the monitor by unplugging the B.D.I. connector from the lead wire connector.
- b. Clean the rupture disc sealing areas of both the sanitary fitting inlet and outlet. These surfaces must be completely clean and free of all rust, corrosion, and foreign material to ensure a proper seal. Do not use scraper or abrasives.
- c. Inspect the rupture disc sealing areas for nicks, scratches, or pitting. If any of these conditions are present, do not install the rupture disc.
- d. Remove any adhered gasket material from previous installation.

B. Installation of the SANITRX HPX Rupture Disc into the System (See Figure B)

NOTE: WHEN INSTALLING THE RUPTURE DISC BETWEEN SANITRX FERRULES, THE FLAT SIDE OF THE FERRULES MUST FACE THE RUPTURE DISC.

- a. Before placing the SANITRX HPX rupture disc into the system, ensure that the gasket surfaces are clean and free of all corrosion and foreign material.

CAUTION: ASSURE THAT THE FLOW DIRECTIONAL ARROWS ON THE RUPTURE DISC THREE-DIMENSIONAL TAG POINT IN THE VENT DIRECTION OF THE RELIEF SYSTEM.

- b. If the Sanitary B.D.I. Alarm System is used, visually inspect the adhesion of the strip to the Teflon® seal and the electrical circuit. If the strip has become detached or the circuit has been broken, **DO NOT INSTALL THE RUPTURE DISC.**
- c. Install the SANITRX HPX rupture disc into the sanitary fitting inlet ferrule. Secure the sanitary fitting inlet ferrule, SANITRX HPX rupture disc, and sanitary fitting outlet ferrule with the appropriate size CDC MBC Sanitary Closure, wing nut clamp, or Tri-Clamp™ 13 MHHM or equivalent. For the wing nut clamp, the hinge portion of the clamp must be positioned adjacent to the rupture disc tag. For the MBC Sanitary Closure, either side of the bolted portion of the clamp must be positioned adjacent to the rupture disc tag.

FIGURE 'B'

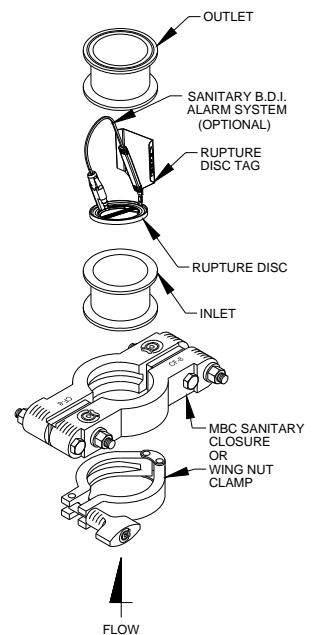

*Teflon is a registered trademark of E.I. du Pont de Nemours and Company used under license.

**Tri-Clamp is a registered trademark of Tri-Clover, Inc.

- d. If the B.D.I. Alarm System is used, installation of the strain relief mounting tab is necessary.
 - a) Before tightening the clamp, install the strain relief mounting tab.
 - b) Slide the mounting tab over the clamp stud as shown in Figure C and then torque as necessary.
 - c) Insert the lead wire into the standoff clip.
- e. If the wing nut clamp is used, torque the wing nut with a calibrated torque wrench to a recommended torque value of 30 In•Lbs / (3.4 N•m) using a 1-5/16" HEX SOCKET.
- f. If the MBC Sanitary Closure is used, install free running bolts and nuts to finger tightness. Torque nuts number 1 and 2 with a calibrated torque wrench at 50% increments of 20 Ft•Lbs / (27 N•m). Based on gasket material type and rupture disc material thickness, the torque compression may close the gap between the clamp halves. If it does not, maintain an equal and parallel gap between the clamp halves throughout the torque sequence. Torque nuts number 3 and 4 using the same criteria as nuts 1 and 2.
- g. If the sanitary B.D.I. Alarm System is used, plug the B.D.I. connector into the lead wire connector using a slight twisting action.

FIGURE 'C'

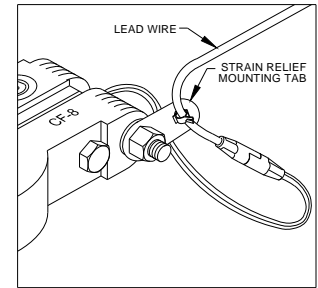

III. Welding Flange Connections

A. Preparation of Sanitary Fittings for Rupture Disc Installation

New Installation

Clean all foreign material from the rupture disc sealing area of both the welding flange and the sanitary ferrule.

Replacement Installation

- a. Disconnect the Burst Disc Indicator (B.D.I.®) alarm strip from the monitor by unplugging the B.D.I. connector from the lead wire connector.
- b. Clean the rupture disc sealing areas of both the welding flange and the sanitary ferrule. These surfaces must be completely clean and free of all rust, corrosion, and foreign material to ensure a proper seal. Do not use scraper or abrasives.
- c. Inspect the rupture disc sealing areas for nicks, scratches, or pitting. If any of these conditions are present, do not install the rupture disc.
- d. Remove any adhered gasket material from previous installation.

FIGURE 'D'
EXAMPLE OF BOLT
TORQUE SEQUENCE

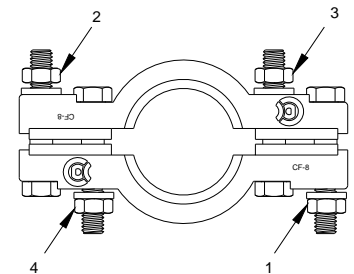

IV. Installation of the SANITRX HPX Rupture Disc into the System (See Figure E)

1. Before placing the SANITRX HPX rupture disc into the system, ensure that the gasket surfaces are clean and free of all corrosion and foreign material.

CAUTION: ASSURE THAT THE FLOW DIRECTIONAL ARROWS ON THE RUPTURE DISC THREE-DIMENSIONAL TAG POINT IN THE VENT DIRECTION OF THE RELIEF SYSTEM.

2. Visually inspect the adhesion of the strip to the Teflon® seal and the electrical circuit. If the strip has become detached or the circuit has been broken, **DO NOT INSTALL THE RUPTURE DISC.**
3. Install the SANITRX HPX rupture disc into the welding flange, dome side down, as shown. Secure the SANITRX HPX rupture disc, the sanitary fitting outlet ferrule, and the locking ring onto the welding flange. Make sure the tag extension is aligned with a groove in the welding flange.

FIGURE 'E'

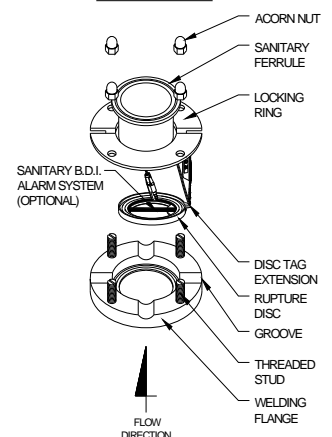

- Installation of the strain relief mounting tab is necessary.

Before installing nuts, install the strain relief mounting tab. Slide the mounting tab over the threaded stud, as shown in Figure F, and then torque each nut as necessary (see Step 5). Insert the lead wire into the standoff clip.

- Torque each nut with a calibrated torque wrench in a cross torquing pattern to the recommended torque value shown below. The gaps between the locking ring halves and the welding flange must be equal during torquing.

| SIZE | TORQUE |
|--------|-----------------------|
| 1" | 30 In•Lbs / (3.4 N•m) |
| 1-1/2" | 30 In•Lbs / (3.4 N•m) |
| 2" | 42 In•Lbs / (4.8 N•m) |
| 3" | 46 In•Lbs / (5.2 N•m) |

FIGURE 'F'

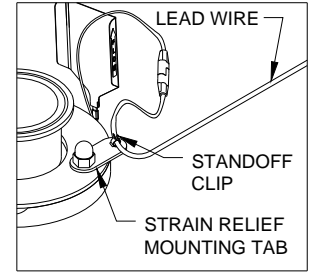

- Plug the B.D.I. connector into the lead wire connector using a slight twisting action.

V. Preventative Maintenance

- Risk assessment and an annual rupture disc replacement are recommended. Rupture disc service life is determined by system operating conditions. The effects of severe pressure/vacuum cycles, corrosion, temperature variations, or other adverse conditions must be evaluated by the user through actual service experience to determine optimal service life.
- IF THE RUPTURE DISC IS NOT REPLACED PERIODICALLY WHEN EXPOSED TO THESE CONDITIONS, PREMATURE FAILURE OF THE RUPTURE DISC MAY OCCUR, THEREBY DISCHARGING THE PROCESS MEDIA.**
- To avoid extended downtime, maintain three spare rupture discs in stock at all times for each holder in use. The number of spares required ultimately will be determined by service conditions.

VI. Customer Service

If you wish to discuss your application, installation, or maintenance, please contact the Customer Service Department at one of the addresses shown on the last page of these instructions.

SANITRX HPX Rupture Disc incorporates U.S. Patent No. 6,006,938 and 6,241,113 B1; Belgium, Germany, Ireland, Netherlands, United Kingdom Patent No. EP 1 078 183 B1; Hong Kong Patent No. HK1035766

Burst Disc Indicator (B.D.I.) Alarm System incorporates U.S. patent no. Re. 34,308 and 4,408,194; Australia patent no. 539415; Germany patent no. 3174227.0; Belgium, France and United Kingdom patent no. EP 0 033 867; Canada patent no. 1199990; Japan patent no. 2032464.

B.D.I. ALARM SYSTEM OPERATING LIMITS

TEMPERATURE: -40° F to + 400° F MAX CURRENT: 50 Milli Amps
 (-40° C to + 204° C) MAX VOLTAGE: 24 VDC RMS

BURST DISC INDICATOR (B.D.I.®): Sizes 25mm through 900mm (1 inch through 36 inches)

Marked:  II 2 G D EEx ia IIC
 (Tamb = -40° C to +204° C)

EC Type Examination Certificate: ITSO3ATEX 21357U

FULFILLS THE REQUIREMENTS OF DIRECTIVE 94/9/EC (ATEX) FOR: COMPONENTS of equipment and protective systems intended for use in potentially explosive atmospheres.

APPLIED HARMONIZED STANDARD: EN 50 014: 1997 + Amds 1 & 2 General Requirements
 EN 50 020: 2002, Intrinsic Safety

ADDITIONAL INFORMATION: Conformity assessment performed by Notified Body no. 0359, ITS Testing and Certification Limited, Leatherhead, Surrey, UK.



**Continental Disc[®]
Corporation**

Performance Under Pressure[®]



First Certified in 1992



ASME Code Symbol Stamp
If stamped, this product is built in accordance with the requirements of the ASME Boiler and Pressure Vessel Code, Section VIII, Division 1.



3A Sanitary Standards Stamp
If stamped, this product is in full compliance with the 3A standards, Serial #60-00, of the International Association of Milk, Food, and Environmental Sanitarians, Inc.



European Union CE Mark
If stamped, this product is certified to conform to the essential requirements of the Pressure Equipment Directive

Continental Disc Corporation has representatives located throughout the world.
Contact the C.D.C. office nearest you for the authorized representative in your area.

CORPORATE HEADQUARTERS

Continental Disc Corporation

3160 W. Heartland Drive
Liberty, Missouri 64068-3385 USA
Phone: (816) 792-1500
FAX: (816) 792-2277 / 5447
E-mail: pressure@contdisc.com
Website: www.contdisc.com

THE NETHERLANDS

Continental Disc Corporation
Energieweg 20
2382 NJ Zoeterwoude-Rijndijk
The Netherlands
Phone: +(31) 71-5412221
FAX: +(31) 71-5414361
E-mail: cdcni@contdisc.com

CHINA

Continental Disc Corporation
Room 910, Tower B, COFCO Plaza
No. 8 JianGuoMenNei Avenue
Beijing (100005)
P.R. China
Phone: +(86) 10 6522 4885
Fax: +(86) 10 6522 2885
Mobile: +(86) 137 0103 8871
E-mail: cdcchina@contdisc.com

DUBAI

Continental Disc Corporation
P. O. Box 2234
Dubai, U.A.E.
Phone: +(971) 4 280 9023
Fax: +(971) 4 280 9028
Mobile: +(971) 508129525
E-mail: cdcme@contdisc.com